

84" TRIPLEX – CE OWNER'S MANUAL

INCLUDES OPERATION & MAINTENANCE

NATIONAL MOWER CO. 700 Raymond Ave., P.O. Box 14299, St. Paul, Minnesota 55114-0299 USA
Phone (651) 646-4079 – Fax (651) 646-2887

JANUARY – 1999

NATIONAL MOWER COMPANY

ONE YEAR LIMITED WARRANTY

For the period of one year from the date of purchase (45 days if the product is used for rental purposes), National Mower Company will repair or replace free of charge, for the original purchaser, any part or parts found by inspection to be defective by our Factory Authorized Service Station or by the Factory at St. Paul, Minnesota, USA to be defective in material or workmanship or both. All transportation charges on parts submitted for repair or replacement under this warranty shall be paid for by the purchaser.

This warranty does not include engines, engine parts or tires which are covered under separate warranties furnished by their manufacture or supplier.

All service under this warranty will be furnished and performed by our Factory Authorized Service Stations.

-THERE IS NO OTHER EXPRESS WARRANTY-

IMPLIED WARRANTIES, INCLUDING THOSE OF MERCHANTABILITY AND FITNESS FOR A PARTICULAR PURPOSE, ARE LIMITED TO ONE YEAR FROM PURCHASE OR 45 DAYS IF THE PRODUCT IS RENTED AND TO THE EXTENT PERMITTED BY LAW, ANY AND ALL IMPLIED WARRANTIES ARE EXCLUDED. THE ABOVE REMEDY OF REPAIR AND REPLACEMENT OF DEFECTIVE PARTS IS THE PURCHASER'S EXCLUSIVE REMEDY FOR ANY DEFECT, MALFUNCTION OR BREACH OF WARRANTY. LIABILITY FOR INCIDENTAL OR CONSEQUENTIAL DAMAGES UNDER ANY AND ALL WARRANTIES IS EXCLUDED TO THE EXTENT PERMITTED BY LAW.

NATIONAL MOWER COMPANY
700 Raymond Avenue, St. Paul, Minnesota 55414, U.S.A.

DECLARATION OF CONFORMITY

According to Directive 89/392/EEC

We NATIONAL MOWER COMPANY

.....
(Name of supplier)

700 Raymond Avenue, St. Paul, Minnesota 55114 U.S.A.

.....
(Full address of the manufacturer—authorized representative in the community must also give the business name and address of the manufacturer)

declare under our sole responsibility, that the product

84" NATIONAL TRIPLEX MOWER

.....
(Make and model)

to which this declaration relates corresponds to the relevant basic safety and health requirements of the Directive 89/392/EEC, (if applicable) and to the requirements of other relevant Directives:

EN292-1&2--EN294--EN349

.....
(Title and/or number and date of issue of the other Directives)

(If applicable)

For the relevant implementation of the safety and health requirements mentioned in the directives, the following standard(s) and/or technical specification(s) has (have) been respected:

ANSI B71.4

.....
(Title and/or number and date of issue of standard(s) and/or technical specification(s))

1/2/99



.....
(Place and date of issue)

.....
(Name, function and signature of the authorized person)

TABLE OF CONTENTS

Warranty	3
Letter Of Conformity	4
Table Of Contents	5
Specifications	
Dimensions – Mower	6
Engine – Briggs & Stratton 303447	6
Disposal Numbers	6
Noise Emission and Vibration	6
Decal (Transfer) Identification	7–9
Safe Operating Practices	10
Introduction	11
Receipt Of Shipment	11
Assembly Instructions	
Rear Mower	13
Wing Mower	13
Seat	13
Wing Mower Lift	13
Tires	13
Engine Crankcase	13
Fuel Tank	13
Differential	13
Operation	14–15
Maintenance	
Lubrication	16–17
Adjustments	
Foot Brake	17
Parking Brake	17
Steering Gear	17
Wing Mower Belt Tension	17
Wing Mower Pivot Operation	18
Rear Axle Radius Rods	18
Rear Mower Drive Belt Tension	18
Main Drive Belt Tension	19
Chain and Clutch Adjustments	19
Height Of Cut	19
Reel To Bed Knife Adjustment	19
Reel End Play Adjustment	20
Tires and Wheels	20
Wing Mower Lift Adjustment	20
Grinding	20
Bed Knife Replacement	21
Lapping Procedure	21
Optional Equipment	
Roller Scraper Kit & Anti-scalp Roller Kit	22–23
Electrical System	24–25
Troubleshooting	26
Parts List	
Ordering Information	27
Frame, Steering and Running Gear	29
Clutch Drive	31
Gear Shift and Brake	33
Lower Countershaft Assembly	34
Steering Gear Assembly	35
Differential and Rear Axle	37
Rear and Wing Mowers	39
Rear Mower Lift and Drive Parts	41
Battery and Electrical Parts	42
Manual Wing Mower Lift	43
Optional Roller Scraper Kit, and Optional Anti-Scalp Kit	44
Skids, Reel End Shields and Guards	45
Notes	46

SPECIFICATIONS

DIMENSIONS & WEIGHT—Mower

Overall Length	92-1/8" (234 cm)
Width, Wing Mowers Folded	70" (178 cm)
Width, Wing Mowers Down	93" (236 cm)
Height	44" (112 cm)
Weight (Empty)	240 lbs. (528 kg)

ENGINE—Briggs & Stratton Vanguard 303447

Engine Type	Forced Air Cooled, 4-cycle, Horizontal Shaft, OHV Engine
Number Of Cylinders	Two
Bore and Stroke	2.68" x 2.60" (68 x 66 mm)
Piston Displacement	29.3 cu. in. (480 cc)
Maximum Horsepower	16 hp (11.93 kW)
Fuel	Unleaded Gasoline (Petrol)
Fuel Tank Capacity	4 U.S.Gal.(15.14 l)
Oil	Engine Oil SAE 10W-30
Oil Capacity	56 U.S. oz.(1.7 l)
Carburetor	Float Feed
Ignition	Magnetron® Electronic
Spark Plug	RC14YC
Starter	Electric
Governor	Mechanical
Air Cleaner	Dual Element
Muffler	Super Lo-Tone™ with Guard
Net Weight	72 lbs. (32.4 kg)
Dimensions (Length x Width x Height)	12.75" x 15.98" x 17.28" (324 x 406 x 439 mm)

DISPOSAL NUMBERS

Gasoline (Petrol), Lead Free	54104
Engine Oil	54112
Fiberglass Parts	57103
Tires	57502
Gear Oil	54112
Grease	54202
Plastic Tanks	57127

NOISE EMISSION AND VIBRATION

Sound*:	Operator Position (LPA)	82 dBA
	Sound Power Level (LWA)	97 dBA
Vibration*:	Maximum Vibration	16.1 m/s ² RMS
	Location	Left Hand

*Operating Condition: Engine rpm—3100, Unit Stationary

TRANSFER IDENTIFICATION

1

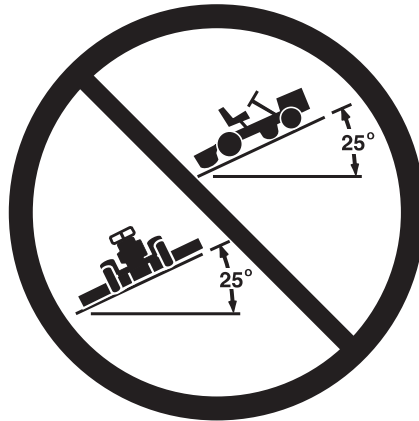

2



3

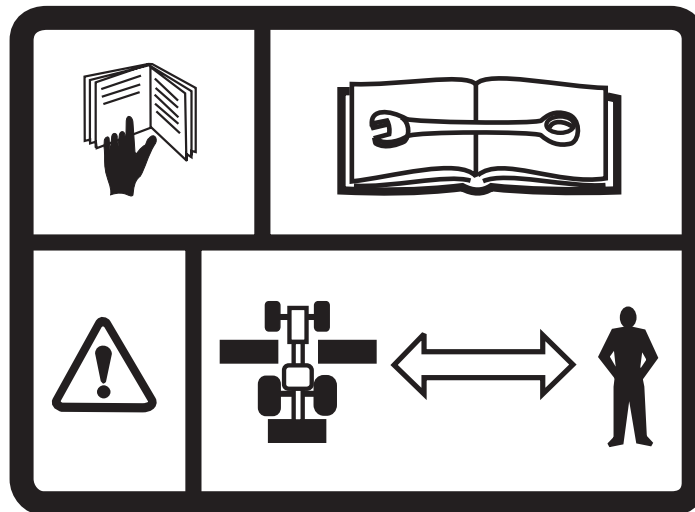

4



5



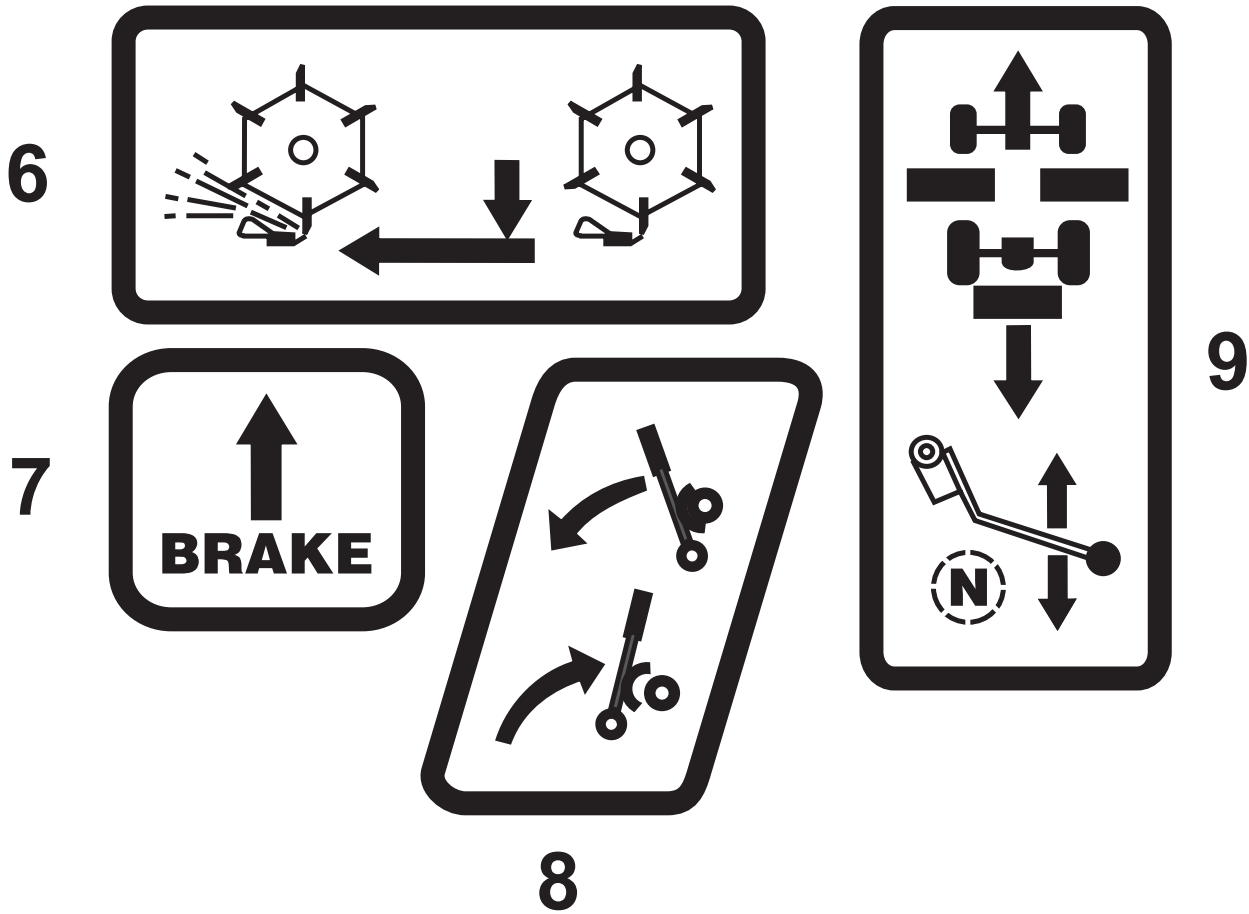

NO.	PART NO.	TRANSFER DESCRIPTION
1	07358	Do not exceed 25° slope. Located on main belt shield.
2	07372	Manufacturer's identification and specifications. Located on the main belt shield.
3	07358	Read Operator's Manual. Refer to manual for adjustments. Caution: Machine is used only as a lawn mower. Keep away bystanders. Located on main belt shield.
4	07371	Sound power level. Located on main belt shield.
5	07371	Sound Level, operator's position. Located on main belt shield.
6	07373	Rear mower clutch engagement. Located on the rear mower belt shield.
7	07373	Foot brake engagement. Located on main belt shield.
8	07373	Parking brake engagement. Located on the left side of the seat support.
9	07373	Main clutch lever. Located on the main belt shield.

Transfer Identification Continued

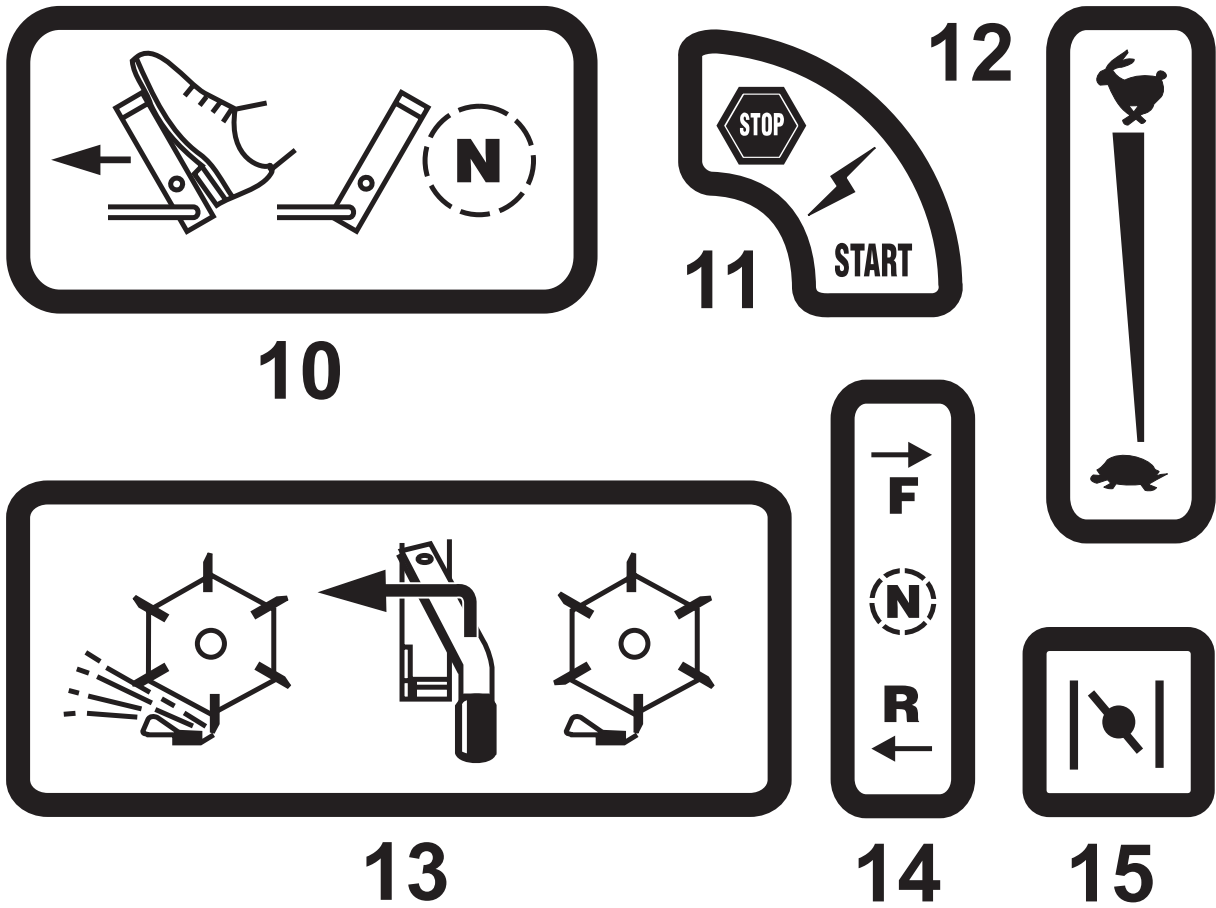

NO.	PART NO.	TRANSFER DESCRIPTION
10	07373	Transport clutch pedal. located on engine pulley shield.
11	07373	Ignition on, start and stop. Located on dashboard.
12	07373	Throttle control, fast to slow. Located on dashboard.
13	07373	Wing mower clutch engagement. Located on left foot rest.
14	07373	Differential shift. Located on shift lever.
15	07373	Engine choke. Located on dashboard.

IMPORTANT

National Mower Safe Operation Practices For Riding Mowers

1. Know control functions and how to stop quickly. READ THE OWNER'S MANUAL.
2. Wear approved safety glasses or goggles when operating the mower.
3. Do not allow children to operate mower. Do not allow adults to operate mower without proper instruction.
4. Do not carry passengers. Keep children and pets at a safe distance from an operating mower.
5. Clear the work place of objects which might be picked up by the blades and thrown.
6. Disengage all reel clutches and shift into neutral before attempting to start the engine (motor). Disengage main clutch before shifting reel clutches.
7. Disengage power to the reels and stop the engine (motor) before leaving the operator's position.
8. Disengage power to the reels and stop the engine (motor) before making any repairs or adjustments.
9. Disengage power to the reels when transporting or not in use.
10. Take all possible precautions when leaving the mower unattended, such as, shifting into neutral, setting the parking brake, stopping the engine and removing the ignition key.
11. Do not stop or start suddenly when going uphill or downhill. Mow up and down the face of steep slopes – never across steep slopes. **Do not exceed a slope of 25° in any direction.**
12. Reduce travel speed on slopes and in sharp turns to prevent tipping or loss of control. Use extreme caution when changing direction on slopes.
13. Watch for holes in the terrain and other hidden hazards.
14. Watch for dangerous traffic when crossing or near roadways.
15. Never direct the discharge of material from operating reels toward bystanders nor allow anyone near the mower.
16. Handle gasoline (petrol) with CAUTION - it is highly flammable.
 - a. Use an approved gasoline (petrol) container.
 - b. Never remove the fuel tank cap or add gasoline (petrol) to a running or hot engine. Never fill the fuel tank indoors. Wipe spilled gasoline (petrol) immediately.
 - c. Open garage doors to allow ventilation if engine is run inside – exhaust fumes are dangerous. Do not run engine in any enclosed area.
17. Keep the mower in good operating condition. Make sure that all safety switches are operating properly and all safety guards are in place at all times, except during servicing.
18. Keep all nuts, bolts, and screws tight to be sure that the mower is in a safe working condition.
19. Never store the mower, with gasoline (petrol) in the tank, inside a building where fumes could reach an open flame or spark. Allow the engine to cool before storing in any enclosure.
20. Keep the engine free of grass, leaves or excessive grease to reduce a fire hazard.
21. The mower and reels should be stopped and inspected for damage after striking a foreign object. The damage should be repaired before restarting and operating the mower.
22. Do not change the engine governor settings or overspeed the engine.
23. Proceed as follows when mowing:
 - a. Mow only in the daylight or in good artificial light.
 - b. Never make a cutting height adjustment while the engine (motor) is running.
 - c. Shut the engine (motor) off when removing grass or unclogging reels.
24. This machine is to be used only as a grass cutter or lawn mower.

WARNING– California, USA residents are required by law (CA PRC 4442 & CA H & SC 13005) to equip their engines with spark arresters when operating in flammable vegetation. Arresters must be obtained from your engine dealer and are not available from National Mower Company.



INTRODUCTION

This machine has been designed to meet European CE Safety standards. Metric equivalents are provided wherever possible for users outside the United States.

The manual has been prepared by National Mower Company as an aid to users for set-up, operating, servicing and ordering replacement parts. Additional information

will gladly be furnished by calling or writing the company. Please furnish us with the Model Number, Serial Number and Date of Purchase when contacting us about your machine. Designations of right, left, front and rear are used in the position of the operator sitting in the mower seat.

RECEIPT OF SHIPMENT

Carefully inspect your machine and crate for damage that could have occurred during shipping. If damages or shortages are noted, have the transportation company's representative note this on the bill of lading.

NOTE

Claims for shipping damages must be noted by the consignee at the point of destination and filed with the transportation company.

NOTE—Some guards removed or cut away to show detail

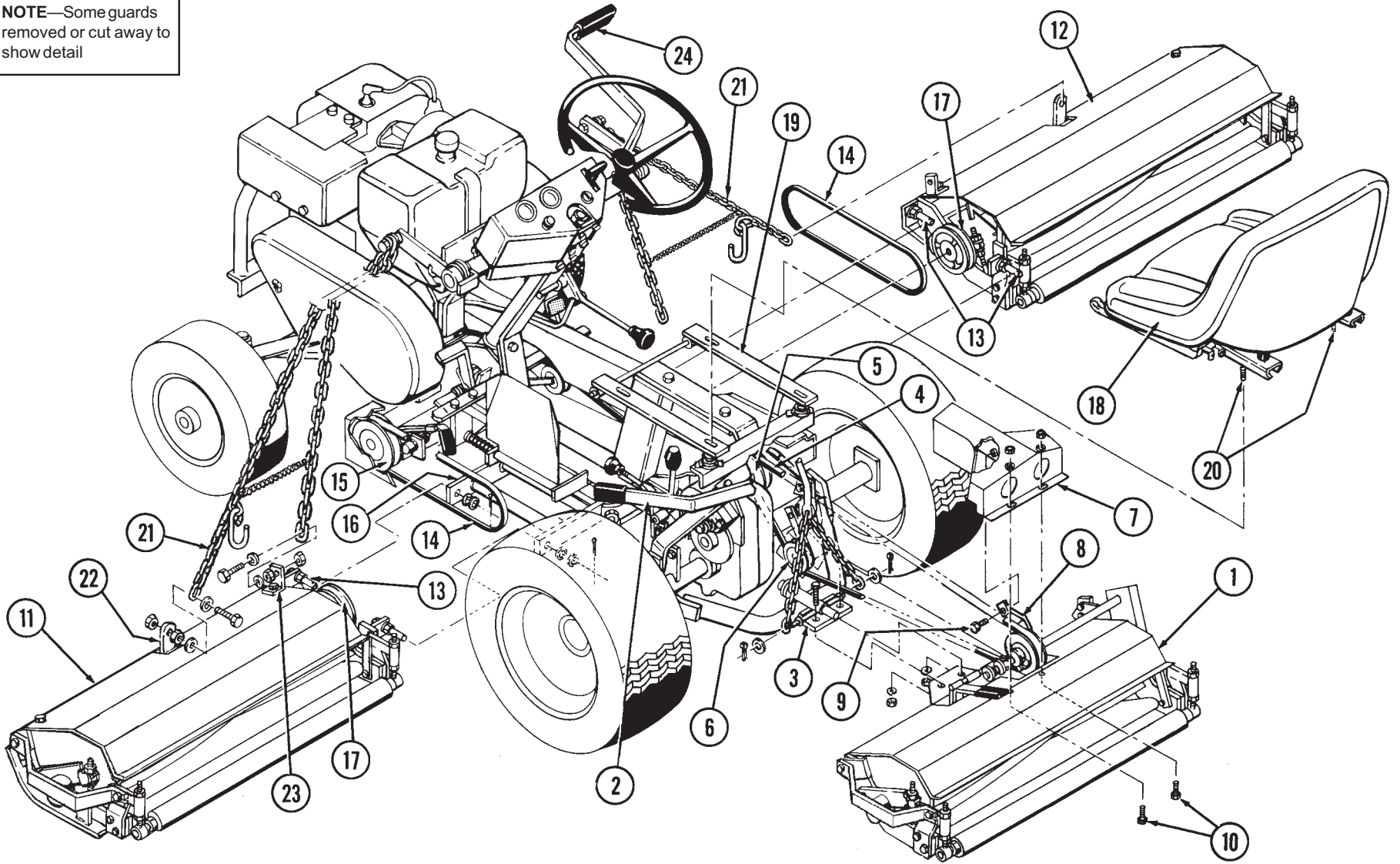

FIGURE A

ASSEMBLY INSTRUCTIONS

REAR MOWER

1. Remove Rear Mower (1, Fig. A) from crate and position behind tractor as shown.
2. Pivot Rear Mower Lifter Handle (2, Fig. A) up and back to lower Rear Mower Pull Plate (3, Fig. A) on the pull yoke. Position mounting flange on the center front of rear mower frame under the pull plate and fasten securely with two fasteners already installed in pull plate.
3. Slip V-Belt (4, Fig. A) over outer portion of Step Pulley (5, Fig. A) located on the right side of differential case. Raise Rear Mower Belt Idler (6, Fig. A) and run V-Belt under idler pulley as shown.
4. Position Rear Mower Clutch Guard (7, Fig. A) over rear mower shaft and pulley area and fasten right side to Support (8, Fig. A) with one 1/4"-20 x 1/2" Round Head Slotted Screw (9, Fig. A). Secure rear flange of guard with two 1/4"-20 x 1/2" Bolts (10, Fig. A), lock washers and hex nuts.

WING MOWERS

1. Remove Left Hand Mower (11, Fig. A) and Right Hand Wing Mower (12, Fig. A) from crate and position on each side of tractor so that Yoke Pins (13, Fig. A) are facing the tractor.
2. Remove the two Wing Mower Belts (14, Fig. A), that are temporarily fastened to the tractor with cable ties, and install over Countershaft Pulleys (15, Fig. A) on each side of tractor. Place other end of belt loosely over end of Wing Mower Pull Yoke (16, Fig. A).
3. Slide left hand and right hand wing mower units into position so that Yoke Pins (13, Fig. A) enter pivot holes in the pull yoke.

IMPORTANT

Forward yoke pins must pass inside belt before attaching pins to pull yokes.

4. Secure Yoke Pins (13, Fig. A) in Wing Mower Pull Yoke (16, Fig. A) with 3/4" I.D. flat washers and 1/4" x 1-1/2" cotter pins. Extra washers are supplied to be used as spacers if needed to allow a snug, but free moving pivot connection. See Figure E, page 18 for more detail.
5. Block mower wheels to prevent mower from moving forward. Pull Wing Mower Assemblies (11 and 12, Fig. A) forward so that Pull Yoke (16, Fig. A) will compress springs. This will allow enough slack to install belts over Reel Pulleys (17, Fig. A).

SEAT

Fasten Seat (18, Fig. A) to slotted holes in Hinge Mounting (19, Fig. A) with the four stud bolts (20, Fig. A) that are installed in the slide assembly with four 5/16" flat washers and four 5/16"-18 lock nuts.

WING MOWER LIFT

Stretch out Lift Chain Assemblies (21, Fig. A) and attach the longest ends to Attachment Tabs (22, Fig. A), located on the middle of the front edge of each wing mower, using 3/8"-24 x 1-3/4" Bolts, 3/8" Flat Washers and 3/8"-24 Hex Nuts. Fasten the shorter length cable to Cable Brackets (23, Fig. A). Position fasteners through ends of chain so that nuts lock on tabs and cable brackets, allowing chain to pivot freely between the flat washers as shown.

Test wing mower lift operation by pulling Lift Lever (24, Fig. A) all the way back (toward the rear). Wing mowers should raise 2" to 3" above level ground. Adjust, if necessary by fastening through another link in the chain at the upper end of lift assembly.

TIRES

See Tire and Wheels, page 20 for proper inflation instructions.

ENGINE CRANKCASE

CAUTION

CRANKCASE OIL HAS BEEN INSTALLED AT THE FACTORY. HOWEVER, IT IS RECOMMENDED THAT ENGINE BE INSPECTED FOR PRESENCE OF OIL AT THE PROPER LEVEL BEFORE STARTING ENGINE.

See Engine Manual for details.

FUEL TANK

Check Engine Manual for correct filling instructions.

DANGER !

Gasoline (petrol) is highly combustible. Do not store or use near an open flame or devices such as a stove, furnace or water heater. Use gasoline (petrol) only in well ventilated areas or outdoors. Wipe up any spills immediately.

DIFFERENTIAL

A gear lube (Mobilplex HD140) has been installed in the differential at the factory. See Maintenance Section, page 16, for additional information.

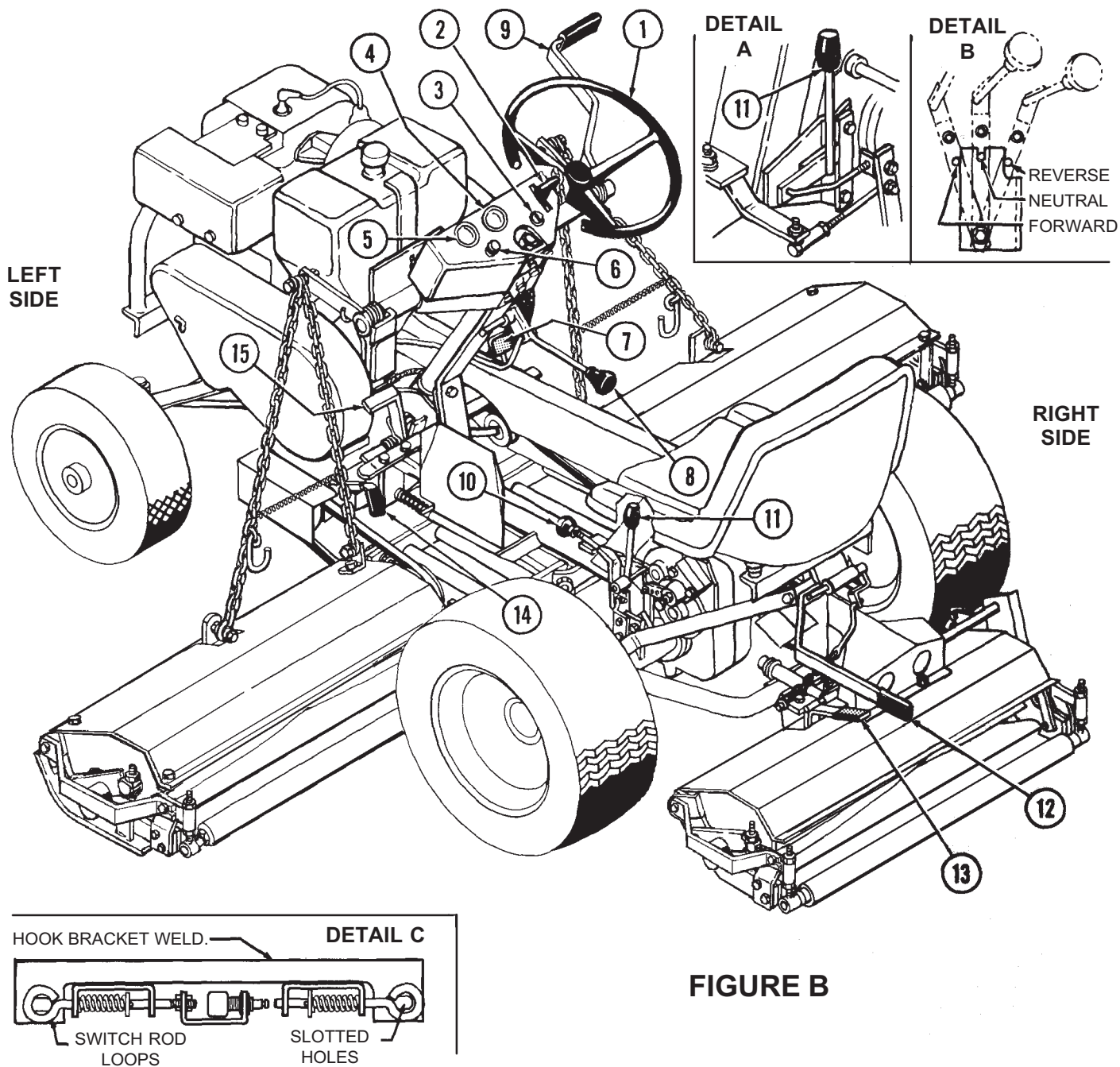

FIGURE B

OPERATION

The following is a description of the machine controls and their function. Refer to Figure B.

1. Steering Wheel

2. Throttle Control - Regulates mowing and travel speeds. Moving lever up and forward will increase speed. Moving lever down and back will reduce engine speed (for starting and idling engine). Never operate the mower at speeds faster than necessary to do a good, safe job.

3. Ignition Lock - Secures the machine electrical system when unattended. Insert and turn key clockwise to turn

ignition on, counterclockwise to off and key removal position.

IMPORTANT

Tractor will not start, even though ignition is on UNLESS:

- A. Transport Clutch is disengaged
- B. Mowing Clutch is disengaged
- C. Operator is seated on the tractor
- D. Wing Mower is disengaged

- 4. **Ampmeter**—Optional
- 5. **Hourmeter**—Optional
- 6. **Choke**—Control and operation is covered in the engine manual.

DANGER !

Moving machinery can be dangerous if not operated properly. Follow all safe operation suggestions as listed on Safe Operation Practices, Page 10.

- 7. **Foot Brake** —Designed to stop the mower. The pedal is depressed with foot to engage. It is necessary to slow the tractor by lowering throttle and disengaging clutch lever before applying brake to prevent excessive wear and engine overload.
- 8. **Main Clutch**—Provides power to the cutting units and tractor drive. Engage clutch by moving lever forward, disengage by moving lever back (toward operator). Use this control during all mowing and slower transporting situations—with or without having the cutting units engaged. **ENGAGE SLOWLY**

IMPORTANT

Advance lever slowly before full engagement. Always disengage this drive before disengaging wing or rear mower drive or when stopping or leaving machine.

- 9. **Wing Mower Lift**—Provides a convenient means of manually lifting the wing mowers a few inches temporarily while the operator remains seated on the mower. It should not be used for trailer transport or storage. Always disengage the wing and rear mower clutches (controls 13 and 14, Page 15) when not mowing and also to minimize reel and bed knife wear. Hooks are provided at the end of each lifting chain for securing wing mowers when transporting or storing the mower. The recommended procedure is as follows:
 1. Stop Mower completely.
 2. Disengage Main Clutch Control (Control 8, Page 15).
 3. Engage Brake Locking Lever (Control 11, Page 15).
 4. Raise Wing Mowers by pulling Lifting Lever fully rearward.
 5. Leave Seat and lift the outer end of each Wing Mower by grasping Handle provided on outer ends of mowers.
 6. Insert the Lift Hook on each Lifting Chain through the slotted holes in the Hook Bracket Weldment and also through the loops of each Switch Rod.

NOTES

- 10. **Differential Shift**—Provides three gear positions: Forward, neutral (center position) and reverse. Move lever forward and to the right (toward operator) until pin is beside metal tab to lock differential in a forward gear. Pin must be located in slot of tab for the neutral position and to the left of the tab (away from operator) for the reverse gear position.

Differential does not have synchro-meshed gears so you have to feel engagement.

CAUTION

Do not shift gears while unit is in motion or damage to differential could result.

- 11. **Brake Locking Lever**—Locks brakes in engaged position. Depress brake pedal fully. Brake lever will lock when lever is moved forward fully so that it travels over center. Refer to Detail A of Figure B.

- 12. **Rear Mower Lifter Handle**—Raises rear mower to the transport position. Pull handle up, forward and over center to lock in an UP position.

- 13. **Rear Mower Clutch Shift Lever**—Engages drive to rear mower. Pull lever forward and away from center of machine to disengage clutch jaw. To engage, pull lever forward and toward the center of machine to engage locking pin.

- 14. **Wing Mower Clutch**—Engages drive to wing mowers. Raise lever and spring action will move lever out to engaged position. Disengage clutch by moving lever toward center of the machine, over stop and down to lock position.

CAUTION

Never engage drive unless wing mowers are in the lowered, cutting position.

15. TRANSPORT CLUTCH PEDAL

CAUTION

FOR TRANSPORT ONLY. Use when mowers are Up and Disengaged. **DO NOT USE FOR MOWING!**

Disengage Main Mowing Clutch (control 8) and shift to forward gear (control 10). *Slowly* move left foot forward to engage and back to disengage. Control disengages automatically when left foot is lifted.

MAINTENANCE

LUBRICATION

Figure C shows the top view of the 84" Triplex, model CE with guards removed. Lubricate your tractor at the recommended locations and intervals using the proper lubricants so that maximum service and long life of the machine may be obtained.

CAUTION

Before doing any work on your machine, stop the engine, remove the ignition key, place differential in neutral and lock brakes.

IMPORTANT

Good maintenance starts with daily attention. A Daily Checklist form has been included with this manual

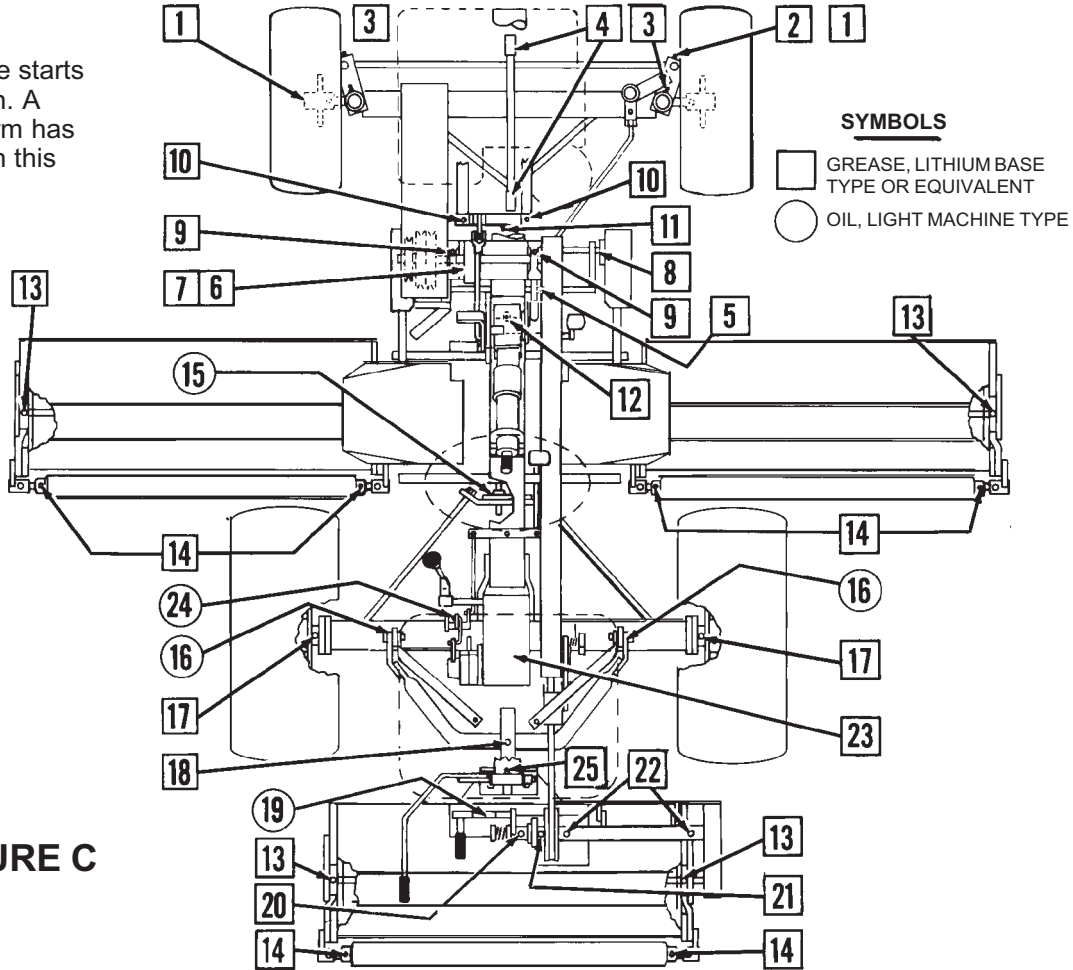

FIGURE C

Item	Frequency (Hrs.)	Location	No. Of Places
1	8	Front Wheel Bearing	2
2	30	Tie Rod	2
3	30	Front Axle King Pin Bushing	2
4	30	Front Axle Pivot	2
5	30	Drag Link	2
6	8	Lower Countershaft Sprocket	1
7	8	Sliding Clutch Jaw	1
8	8	Lower Countershaft Bearing	2
9	30	Pillow Block Bearing	2
10	30	Clutch Pivot Carrier	2
11	30	Main Clutch Idler Arm	1
12	Year	Steering Sector (Grease Fitting)	1
13	8	Reel Roller Bearing	6

Item	Frequency (Hrs.)	Location	No. Of Places
14	8	Roller Bracket Bushing	6
15	8	Wing Mower Pull Rod Bush. (Fig. E)	4
16	30	Pull Yoke Pivot	2
17	30	Rear Axle Outer Bearing	2
18	30	Rear Mower Pull Yoke Pivot	1
19	30	Rear Mower Clutch Lever Bracket	1
20	8	Rear Mower Sliding Jaw Clutch	1
21	8	Rear Mower Countershaft Pulley	1
22	8	Rear Mower Countershaft	2
23	—	Differential, See Page 17	1
24	30	Brake Linkage Pivot	1
25	30	Rear Mower Lifter Bracket	1

DIFFERENTIAL GEAR LUBE

Since the tractor does not operate at high speeds the lube level in the differential is not critical as long as there is enough lubrication to coat the gears. 1-1/2 pints of gear lube have been installed in the differential before leaving the factory. Unless leakage is evident, it is recommended that lube level be checked once a year by removing inspection plug in the differential case and seeing if lube is up to the hole. Add a good quality lube such as 85W-140 or 90W or equivalent, if necessary, through the top filler plug.

STEERING GEAR LUBRICATION - See Fig. D

The steering gear has been redesigned and location of the grease zerk is more easily accessible. Although the factory has installed 1/4 lb. of grease into gear housing before shipment, it is recommended that housing be inspected for adequate grease or contamination at least once every year and filled with a Lithium base type grease or equivalent. Inspection and parts replacement require disassembly as follows:

1. Remove three cap screws that hold steering gear to frame. Remove brake pedal, main belt shield and entire steering assembly from the machine.
2. Remove 3/4" Hex Jam Nuts (2) and steering cam from gear housing while leaving steering assembly in place on mower. Add grease or repack as necessary.

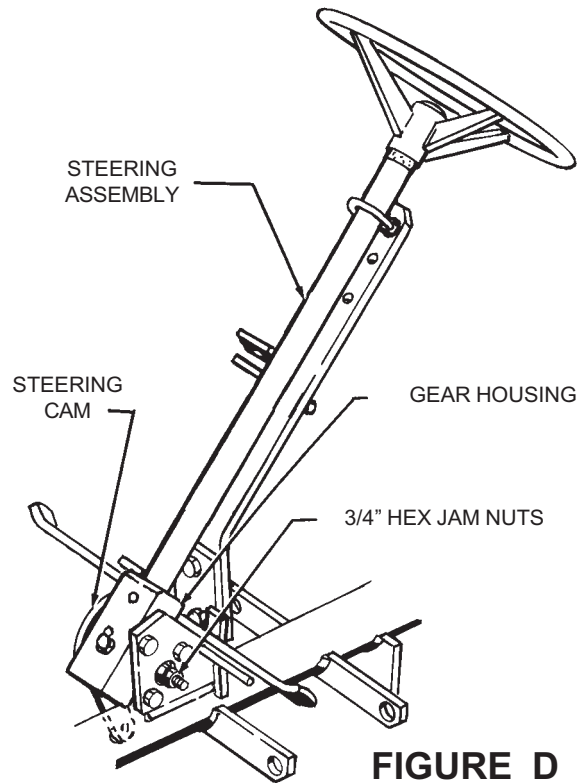

FIGURE D

ADJUSTMENTS

DANGER !

To ensure safety, all of the following adjustments must be made only after the engine clutch lever has been disengaged and the ignition key and spark plug wire have been removed.

FOOT BRAKE ADJUSTMENT

Foot operated Brake (Item 19, Fig. 3 in Parts List) can be adjusted to compensate for brake pad wear by loosening the Locking Nut with a 11/16" wrench on Brake Caliper (Item 2, Fig. 3) and raising Brake Caliper Arm. If necessary, additional brake take-up can be made with Lower Linkage Brace (Item 15, Fig. 3) by loosening Locking Nut with a 7/16" wrench and turning brace in or out. Retighten Locking Nut.

Contact your dealer or National Mower Co. for brake replacement parts.

PARKING BRAKE

Tension on Parking Brake (25, Fig. 3 in Parts List) should be just tight enough to hold the over-center position when engaged. Adjustment may be made by loosening the two jam nuts on the Formed Rod (14, Fig. 3) and turning rod in or out. Retighten Jam Nuts.

STEERING GEAR ADJUSTMENT

Steering wheel and front wheel alignment is accomplished by first positioning the front wheels straight ahead.

Then, loosen the hex jam nuts on Pin (See Fig. D) and turn pin in toward the housing until it contacts worm gear. Back off pin 1/4 turn and retighten jam nut on pin.

WING MOWER BELT TENSION

Proper belt tension allows mowers to be driven without slippage but loose enough to be deflected slightly at a point midway between pulleys. An overly tight belt will cause excessive bearing wear and a slipping belt causes excessive belt wear. Never allow oil to get on the belt which could cause slipping.

Figure E shows the left wing mower belt and pivot area. Normally, if wing mowers are sliding freely on Pull Rods (1, Fig. E), the pull yoke Springs (2, Fig. E) provide proper belt tension. If slippage occurs, it could be due to a weakened spring or a stretched belt.

Spring tension may be increased by removing Cotter Pins (3, Fig. E) in pull rods, loosening Set Screws (4, Fig. E) in bottom of Pull Yoke (5, Fig. E), and sliding pull rods rearward until sufficient 3/4" I.D. washers can be added between Springs (2, Fig. E) and Pull Rod Bushings (6, Fig. E) to tighten springs.

NOTE

When pull rods are readjusted, allow 1-1/2" clearance between frame member and Cotter Pin (3, Fig. E) on front of pull rods, as shown in Detail A, before tightening set screws. A badly worn belt should be replaced.

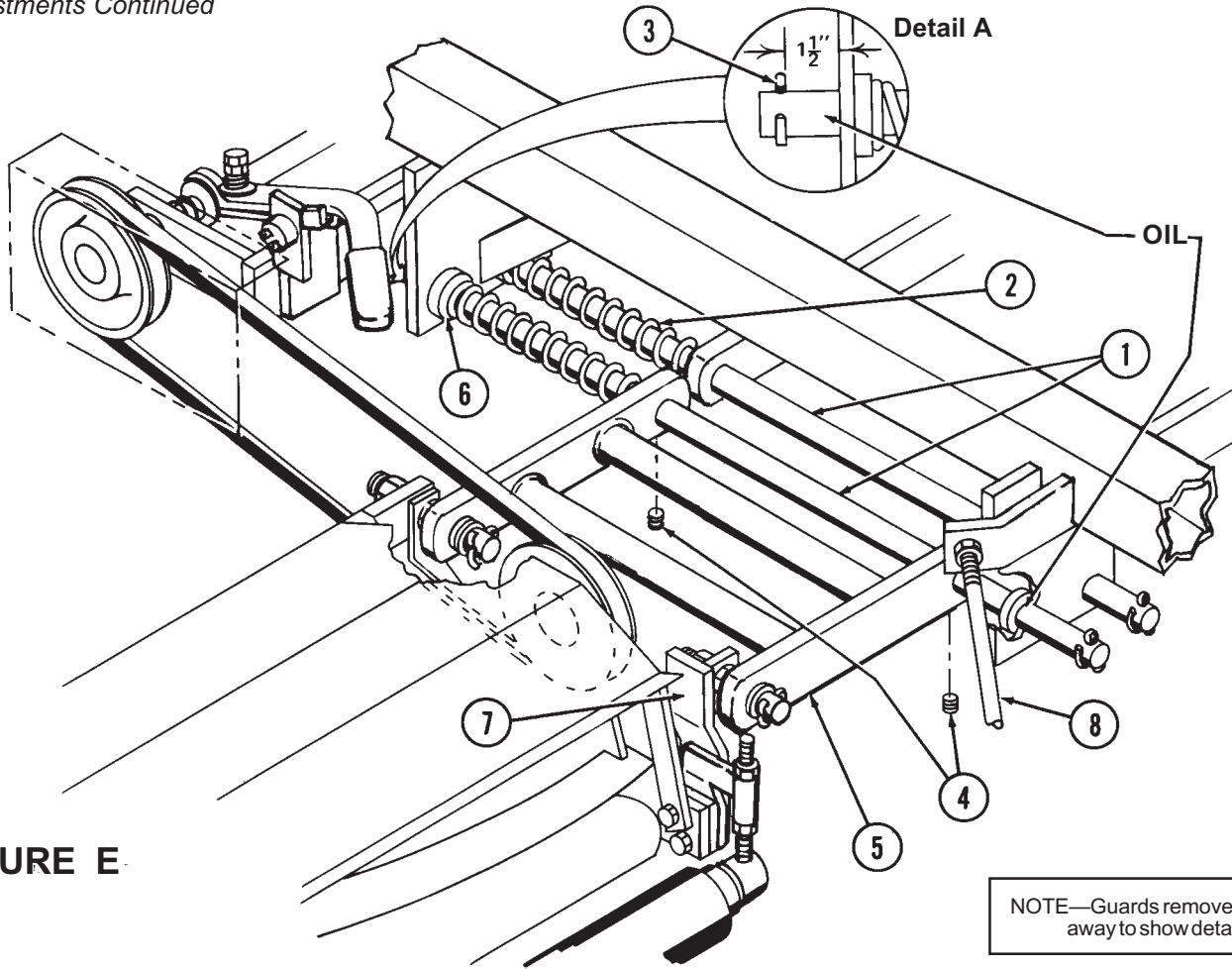

FIGURE E

NOTE—Guards removed or cut away to show detail

IMPORTANT

Clean and oil pull rods frequently and check to see that pull rods are sliding freely. Also check for bent pull rods that could cause them to bind in the bushings.

Brackets (7, Fig. E) periodically to see that they are not bent. Severe blows to wing mowers could cause bending in these areas and prevent proper operation. Straighten or replace parts affected.

WING MOWER PIVOT OPERATION

Check Pull Yoke Arms (5, Fig. E) and Wing Mower Yoke

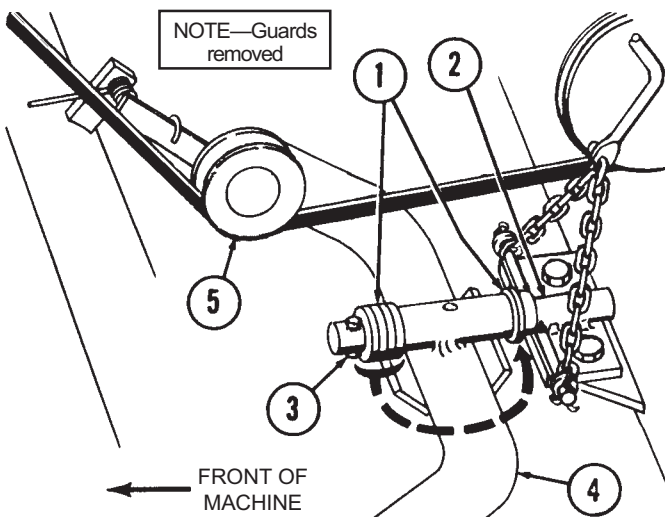

FIGURE F

REAR AXLE RADIUS RODS

Rear Axle Radius Rods (8, Fig. E) are designed to act as struts for the rear axle. Finger tighten strut tension on each side, then wrench tighten lock nuts securely. Excessive tension will cause strain on the rear axle.

REAR MOWER DRIVE BELT TENSION

Follow Wing Mower Belt Tension on page 11 for determining proper belt tension and refer to Figure F. Spacers (1, Fig. F) are provided on the Rear Mower Pull Rod (2, Fig. F) to adjust belt tension. To tighten belt, remove Spring Pin (3, Fig. F) from pivot rod on pull plate, slip rod out of Rear Mower Pull Yoke (4, Fig. F). Move as many spacers as necessary to location indicated and reassemble.

NOTE

Belt Idler Pulley (5, Fig. F) must be pressing down on lower portion of rear mower drive belt as shown.

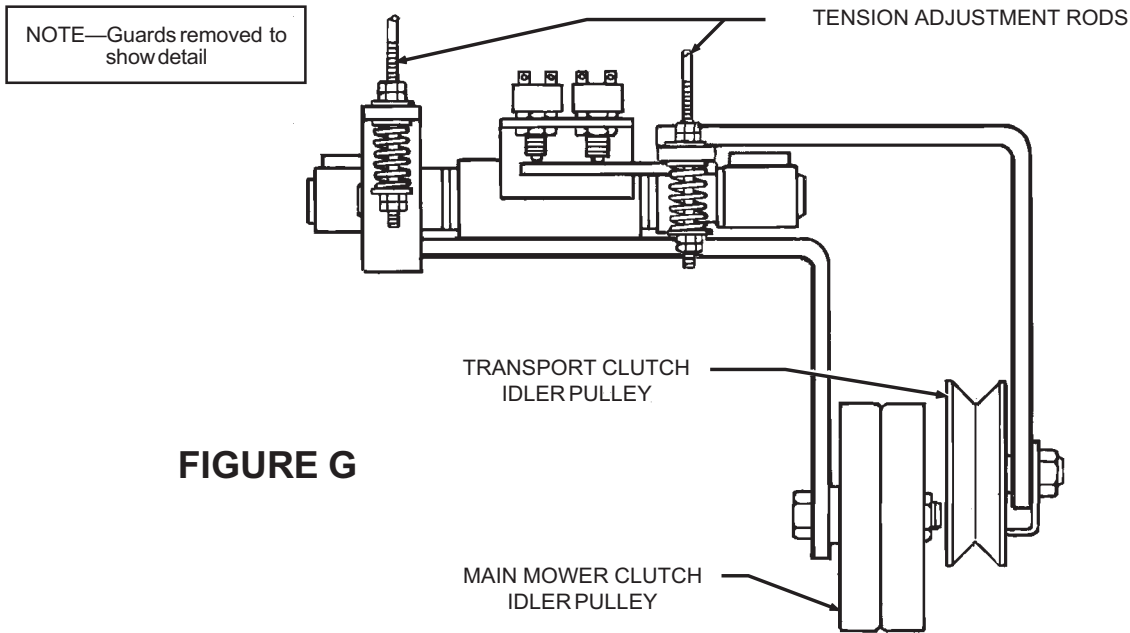

FIGURE G

MAIN DRIVE BELT TENSION

The Main Drive Belt has a spring loaded idler pulley. Further adjustment may be made by loosening mounting bolts for Pillow Block Bearings (See 33, Fig.2 for this and chain adjustment below), sliding bearing forward and retightening bolts. Note: It will probably be necessary to readjust engine belts also.

CHAIN ADJUSTMENTS

The Countershaft Chain (34, Fig. 2) is adjusted by inserting as many Shims (37, Fig. 2) as needed under Pillow Blocks (33, Fig. 2). Rear Mower Chain (17, Fig 8) is adjusted by pivoting Countershaft Housing (19, Fig. 8).

CLUTCH ADJUSTMENTS

If the clutch won't engage because the belts are loose, increase belt tension by loosening engine mounting bolts and sliding the engine forward in slotted mounting holes or move position of Tension Adjustment Rods (See Fig. G). Keep engine square with frame. Test tension after each small change of position.

If the clutch won't disengage because the belts are too tight, decrease belt tension. Move the engine back slightly, toward the rear of the mower, or lengthen one, or both, of the Tension Adjustment Rods. Tighten all bolts and nuts securely.

HEIGHT OF CUT

DANGER !

Reel blades are sharp! Never attempt to adjust cutting height or reel to bed knife while the machine is running.

The height of cut is variable and may be adjusted on both the rear mower and the wing mowers by loosening the top and bottom Adjusting Nuts (1, Fig. H) which hold Roller Adjusters (2, Fig. H) in Roller Brackets (3, Fig. H).

Roller (4, Fig.H) may then be moved up or down.

It is important to get rollers adjusted to the same height so that there will be uniform cutting the entire width of the mower. Do not adjust by sight. Place the mower on a hard, level surface. After loosening Adjusting Nuts (1, Fig. H) on each side of reel assemblies, place a board or gauge plate of the desired height under each bed knife back bar and then tighten nuts.

REEL TO BED KNIFE ADJUSTMENT

The reel is adjusted to a fixed position bed knife. This makes a more rugged and durable frame and retains proper adjustment longer. The Reel Adjuster Bolt (5, Fig. H) regulates reel distance from the bed knife.

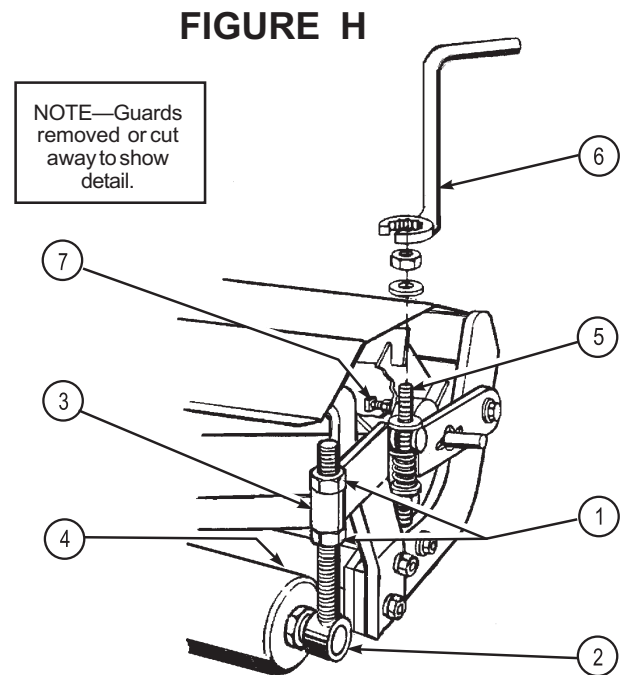

FIGURE H

To reduce the distance, turn the lower locking nut on each side of the reel down with special Reel Adjustment Wrench (6, Fig. H) and then tighten the top nut. Proceed slowly and do not overadjust—about 1/8 of a turn on each side to begin with. Do not adjust one side more than the other unless it is obviously out of alignment and do not get the reel so tight that it is hard to turn by hand. A too tight reel will wear much faster.

DANGER !

Reel Blades are sharp and can cut severely—especially in the area between the reel and bed knife. Wear heavy protective gloves and proceed cautiously.

The reel should “wipe” or lightly touch the bed knife. With belts removed, spin reel by hand. Reel should spin freely, making approximately two revolutions before stopping. By using paper strips held between the reel and the bed knife, check to see if the unit cuts the paper evenly across each reel blade. Make sure the adjusting nuts are tightened before use.

REEL END PLAY ADJUSTMENT

As the reel is used, normal wear of the reel bearings will cause end play. This condition could cause uneven wear to mower parts and uneven cutting of turf.

Test for end play periodically by trying to move the reel from side-to-side in the frame. If there is any movement, adjust by loosening lock nut on Adjustment Bolt (7, Fig. H) which is located on the inside right end of the reels, and turning bolt in one half turn or less. Do not over tighten as it would cause excessive bearing wear. Test again for end play and tighten locking nut if reel is rotating freely and end play is minimal.

TIRES AND WHEELS

All tires are fully pneumatic. For shipment, tire pressure is increased and we suggest that you lower pressure for operation as follows:

8.00 x 12 (rear) = 10 PSI or 650 x 8 (front) = 14 PSI to 28 PSI max. Inflate optional ATV Recreational Tires = 5 PSI maximum.

NOTE

Wheel hubs have been turned in at the factory to facilitate shipment. For added stability on hills, turn wheels out to increase tread width (valve stem should be facing in towards operator).

WING MOWER LIFT ADJUSTMENTS

The chain sections on Lift Wire Assemblies for the wing mowers are used to adjust for the proper lifting action. When wing mowers are down, in operating position, lift wires should have a slight bit of slack.

Adjustment of the Safety Switch (1, Fig. I) may be necessary for correct operation. The safety switch can be adjusted on the Switch Bracket (2, Fig. I) so that when Switch Rods (3, Fig. I) are positioned over slotted holes in the ends of the Hook Bracket Weldment (4, Fig. I) lift hooks can be inserted through loops of switch rods and hook bracket weld. This will close the safety switch and prevent accidental engagement of wing mower blades in transport position.

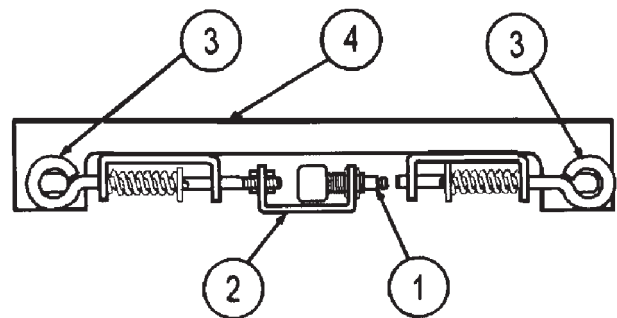

FIGURE I

BACK GRIND IN THE DIRECTION OF THE ARROW AT 25°

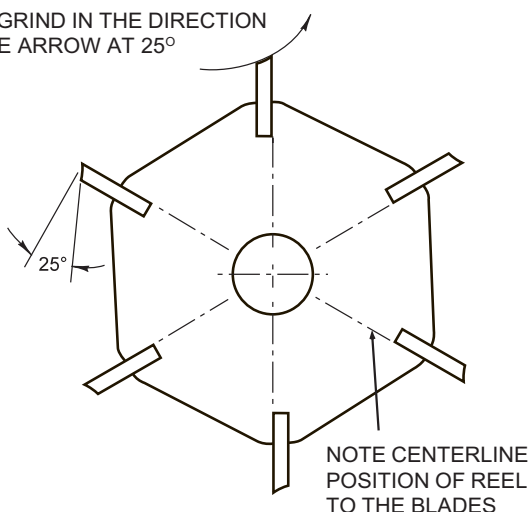

FIGURE J

GRINDING

Reels must be ground at 25° in the direction shown below by the arrow in Figure J. Back grind until reel blades are free from roundness, dents and nicks. Spin grind to remove all burrs. All blades must be on the same diameter.

For maximum cutting efficiency, grind bed knife top and front edges at 5° as shown in Figure K.

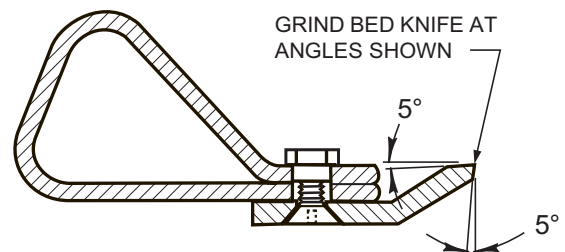

FIGURE K

BED KNIFE REPLACEMENT

When the bed knife becomes damaged or too worn to keep sharp, it must be replaced. Design improvements have made bed knife replacement easier with bolt-on construction. Follow the procedure below.

1. The backbar (1, Fig. F), bed knife (2, Fig. F) and fasteners have been assembled at the factory under tension. To ease replacement and prevent misalignment of components, the leading edge of the backbar must be tack welded two or three places before the old fasteners are removed.
2. Remove shoulder nuts (3, Fig. F) and flat head screws (4, Fig. F). If shoulder nuts are badly rusted or corroded, they may have to be cut off and screws driven out to be removed.
3. Clean the bottom surface of the backbar for maximum metal contact with the new bed bar.
4. Fasten the new bed knife to the bottom of the backbar in the position shown (bent edge up). Shoulder of shoulder nuts must be seated firmly in the backbar and screws must be flush with the bottom of the bed knife.
5. Torque shoulder nuts 35 to 40 ft/lbs.

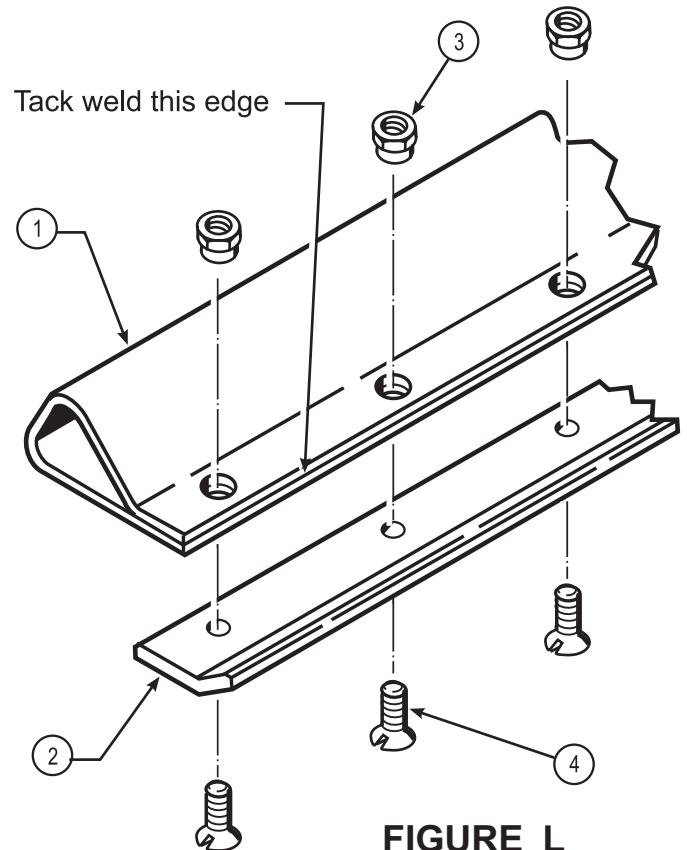

FIGURE L

LAPPING PROCEDURE

INTRODUCTION

Back lapping is a very important step in maintaining sharp reel blades on the rear and wing mowers.

This procedure should be performed when the reel blades and bed knife become slightly rounded and the grass is not cut cleanly with only a slight bed knife adjustment. Also, after grinding the bed knife and reels, you should back lap to establish a perfect match between the bed knife and reel blades.

RECOMMENDED STEPS

1. Make sure to adjust the bed knife to the reel so that the bed knife is level with the reel and light contact is maintained. Reels must be run in a reverse direction to be lapped.
2. Remove Skid Bars (1 & 5, Fig. 13), reel end Mower shields (3, 4, 6 & 7, Fig. 13) and wing mower and rear mower Top Shields.
3. Remove wing mower Drive Belts (3, fig. 4) and rear mower Drive Belt (13, Fig. 8).
4. Attach a back lapping machine (not supplied by National Mower) to the reels, following the instructions furnished by the machine manufacturer.
5. With reels running, apply the lapping compound using

a 2" or 3" brush. Apply the compound evenly to the moving blades.

DANGER !

Be extremely careful not to let the brush, your fingers or your clothing get caught in the reels. Use approved safety glasses to protect eyes from flying particles and abrasives.

Many types of compounds are available for lapping. However, we recommend a good pre-mixed water soluble compound such as. Pre-mixed compound saves the time required to mix, eliminates the waste of abrasive, rinses off easily with water and is available in all grit ranges from coarse to extra fine.

6. Stop the reel and examine both bed knife and reel blades to see that the cutting edges are uniformly sharp. If not, gradually tighten reel adjuster bolts (see Fig. H, Page 19) and repeat Step 5 above until the proper sharpness results.
7. Rinse off the compound thoroughly with water to remove all abrasive. Check for sharpness and readjust the bed knife if necessary.
8. Replace all shields and skid bars.

OPTIONAL EQUIPMENT

ROLLER SCRAPER KIT, No. 480067

Purpose: Clean reel rollers allow more uniform cutting height. This kit is designed to help keep each roller free from clippings and dirt. Scrapers can be replaced easily and economically. Tension is easily adjusted with jam nuts on each end of cable.

Includes: One R.H. and one L.H. Adjusters for each roller
One Roller Scraper Cable for each roller
Four 5/16"-24 Hex Lock Nuts for each cable
Installation Instructions

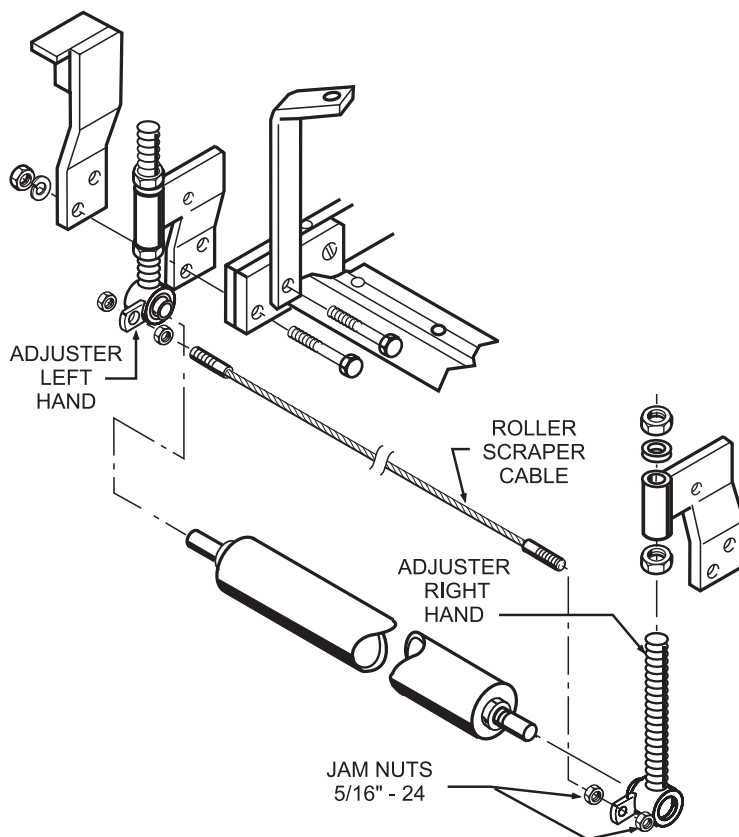

FIGURE M

**ANTI SCALP ROLLER KIT,
No. 480060**

Purpose: This kit is designed to fit on the front of each mower assembly so that it will prevent scalping of turf when cutting heights are very low or when turf contours are severe.

- Includes: Two Front Rollers
Two Front Roller Brackets
Two Roller Bracket Adjusters
One Roller Shaft
Spacers and Fasteners
Installation Instructions

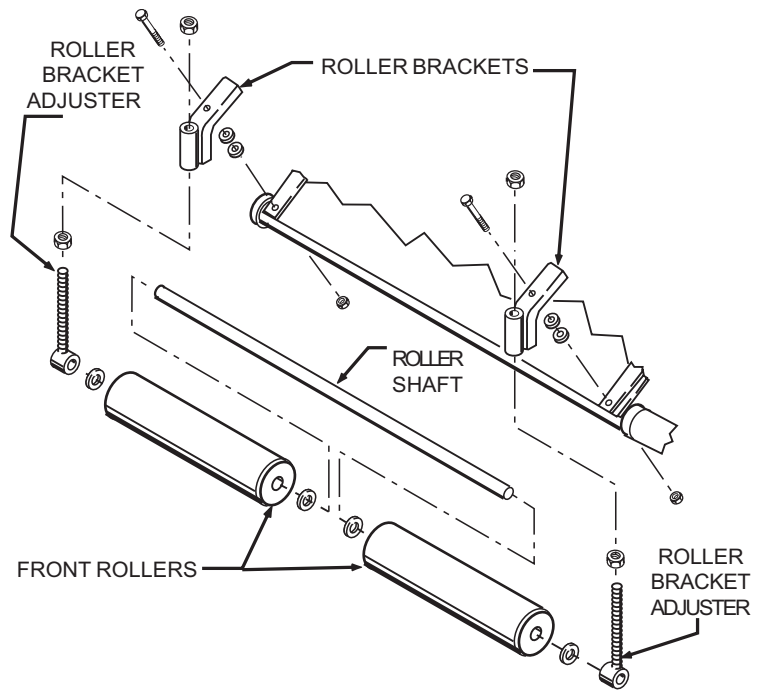

FIGURE N

ELECTRICAL SYSTEM

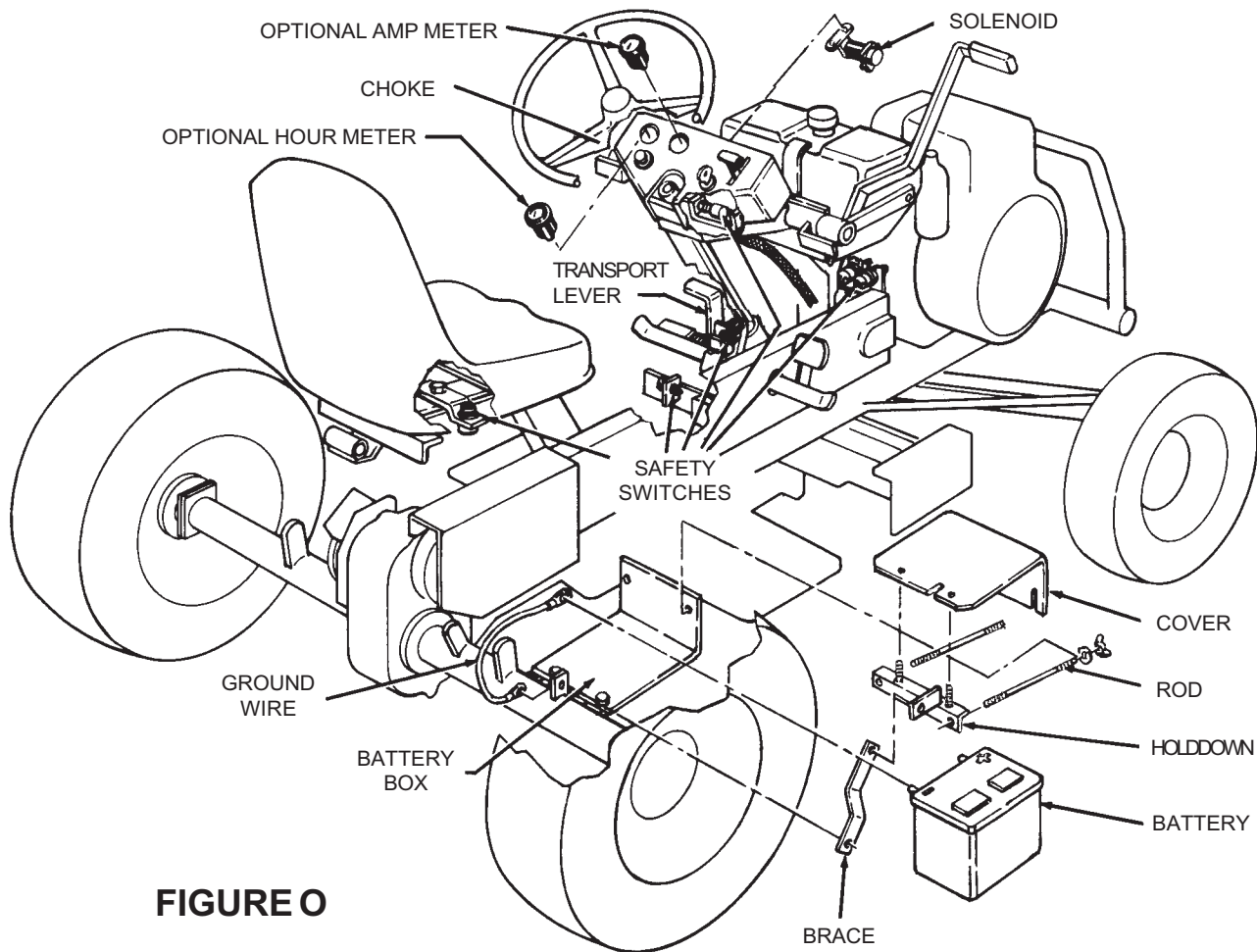

FIGURE O

Figure O illustrates some of the major electrical components of the 84" Triplex. For exact information on electrical components and hook-up for the Briggs & Stratton Engine, refer to Electrical Schematic, Figure P and the engine manual supplied with your particular mower.

The owner must supply their own 12 volt battery. Base dimensions must not exceed 7-1/4" (18.4 cm) x 8-5/8" (22 cm) to fit the battery holder. National recommends a quality battery, side post type, BCI group size 70, such as Exide Side Post Model 70-LT-60 or similar. Dimensions: height-7-3/16" (918.3 cm), width-6-3/4" (17 cm), length-8-5/8" (22 cm). Follow battery maintenance instructions closely for maximum battery life.

Always keep battery covered to protect it, making sure that all supporting and clamping parts are installed in the proper order as shown. See Fig. 9 in the parts section for complete parts identification.

The system is fused with a standard 30 amp fuse, commonly available in most locations.

DANGER !

To prevent accidental electric shock, disconnect battery cable before working on the wiring. Never leave the ignition key in the lock when machine is left unattended.

IMPORTANT

The electrical system consists of 5 safety switches. The engine will not start unless the following conditions are met. Transport Clutch Pedal (43, Fig. 2) must be disengaged (not depressed), Main Clutch (2, Fig. 2) must be disengaged (back position), Wing Mower Clutch (5, Fig. 4) must be disengaged (moved in toward the operator) and Wing Mowers must be raised into transport position with wing mowers secured in Switch Rods (3, Fig. 1) so that the safety switch on the steering column is depressed. As a further precaution, the engine will not start unless the operator is seated (to engage the seat safety switch).

Periodically, check the above switches for proper operation by attempting to start the engine with each switch in the wrong position. If a faulty switch is suspected, check with a continuity tester and replace the switch if necessary.

Another common cause of ignition problems is a loose or poorly grounded connection. Check for good metal-to-metal contact on the grounding wires and check the following Electrical Schematic (Figure P).

TROUBLE-SHOOTING

Tractor Unit

SITUATION	THINGS TO CHECK
Engine will not start	Turn ignition switch to on Ensure that there is sufficient fuel in petrol tank Make sure that all four safety switch are contacting properly – See Electrical System Look for a loose wire on Ignition or spark plug wire not connected
Tractor will not move forward	Gear selector must be in one of the drive positions Engine drive clutch must be engaged (rearward and up) Drive belts too loose (see Main Drive Belt Tension, Page 19) Visually check to see that pulleys are not slipping on shafts If everything above is OK, check for a damaged gear in the gear box
Tractor will not move rearward	Same as above. If all of the above check OK, check the reverse gear in the gear box
Tractor will not stop	Ensure that the main clutch is disengaged (brake will not stop engine) Brake adjustment or service may be needed (see Foot and Parking Brake Adjustments, Page 17)

Cutting Units

Situation	Things To Check
Wing and/or rear mower will not cut	Bed knife to reel position may be out of adjustment (see pages 19 and 20) Drive belts or drive chains may need tightening Visually check that both the drive pulleys and the shafts are rotating
Cutting units will not turn.	Clutches may not be engaged Look for anything that could be jammed between the reel and the bed knife Drive belts or drive chains may need tightening Visually check that both the drive pulleys and the shafts are rotating
Units will not stop turning	Disengage all clutches
Uneven cut	Height of cut not the same on each cutting unit (see page 19) Check to see if any part is bent Something jammed in cutting unit pivots, not allowing them to float

DANGER !

**All adjusting must be made with the engine off.
Do not do any investigation of the working parts of the machine with the motor running. Always turn the engine off!**

PARTS LIST

Note: For your records and future ordering, fill in the following information.

DATE PURCHASED	MODEL NO.	SERIAL NO.

ORDERING INFORMATION

When ordering replacement parts, always furnish:

1. Your complete name, address and phone number.
2. Model Number and Serial Number (stamped on the main frame angle iron near the main clutch).
3. Part Number (it is recommended that the correct number be verified with a current Master Price List).
4. The full Description of the part.
5. Quantity desired (quantity shown is the total number of parts contained in the particular view shown).

If the Part Number and the Description of your order do not agree, the Part Number will be used to fill your order.

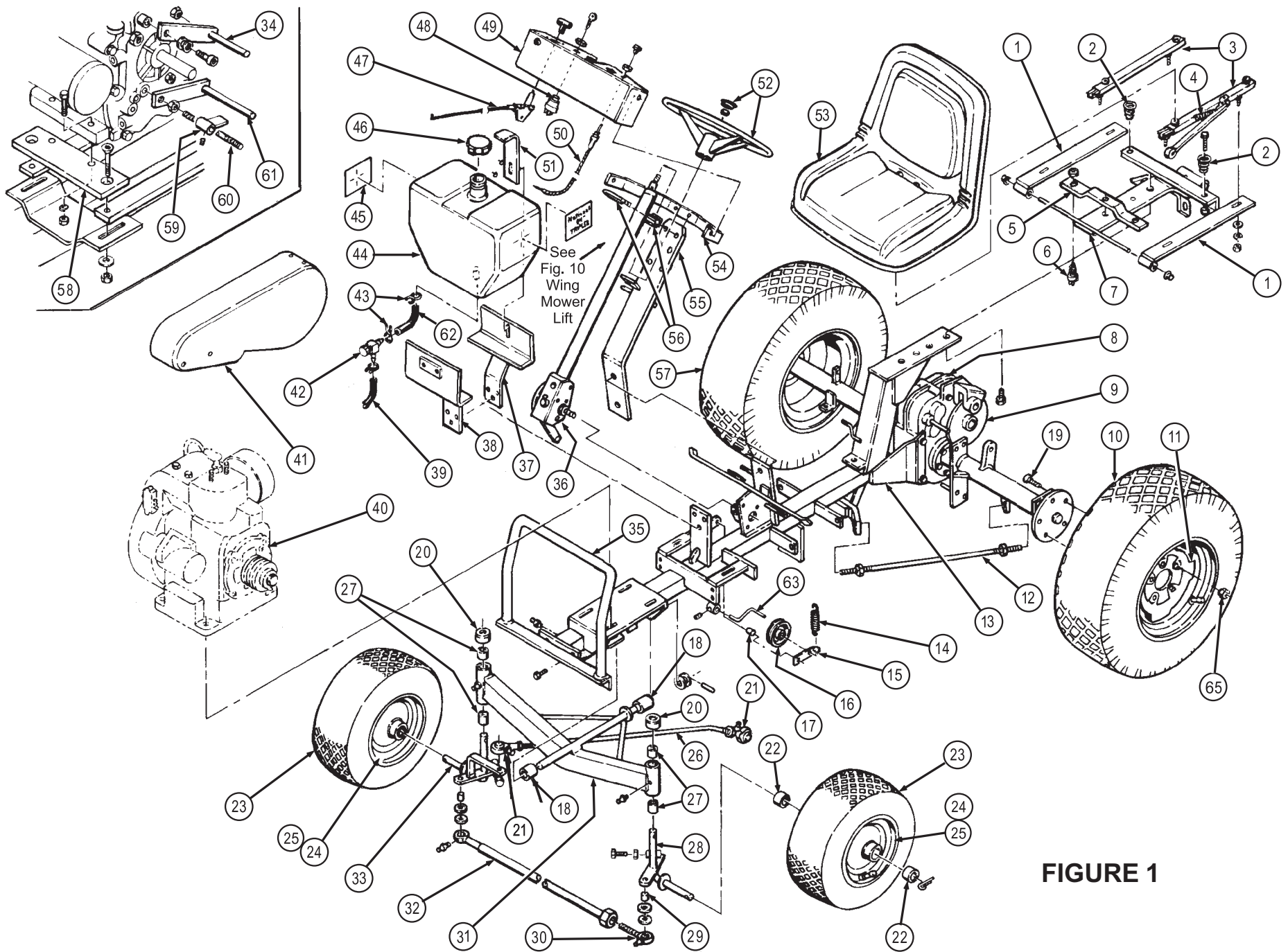

FIGURE 1

FIGURE 1 — FRAME, STEERING & RUNNING GEAR

Item	Part No.	Description	Qty.	Item	Part No.	Description	Qty.
1	200462	HINGE, Seat	2	33	200354	KINGPIN, Right	1
2	04512	SPRING, Seat	2	34	201394	BRACKET, Engine Pulley, Upper	1
3	07101	SEAT ADJUSTER	1	35	200763	FRONT BUMPER, Briggs & Stratton Vanguard	1
4	04528	SPRING, Seat Adjustment Lever	1	36	201141	STEERING GEAR ASSEMBLY, See Figure 5	1
5	200768	BRACKET, Safety Switch	1	37	201121	HOLDER, Gas Tank, Rear	1
6	07090	SAFETY SWITCH, Seat	1	38	201122	HOLDER, Gas Tank, Front	1
7	200444	BRACKET, Rear Mower Lift	1	39	201596	GAS LINE, 1/4" ID, Neoprene, Valve to Carburetor	1
8	—	DIFFERENTIAL & REAR AXLE, See Figure 6	--	40	07117	ENGINE, Briggs & Stratton Vanguard, 14 H.P	1
9	—	BRAKE ASSEMBLY, See Figure 3	--	41	09031	SHIELD, Pulley	1
10	07136	TIRE, Rear, 8 x 12	2	42	07165	VALVE, Inline, Gas	1
11	07073	WHEEL, Rear, 8 x 12	2	43	07175	CLAMP, Fuel Line	4
12	08044	RADIUS ROD, Rear Axle	2	44	07167	TANK, Gas	1
13	200310	FRAME, 84" Triplex	1	45	07076	DECAL, Set	1
14	04501	SPRING, Main Belt Idler	1	46	07176	CAP, Gas	1
15	200184	ARM, Main Belt Idler	1	47	07112	THROTTLE	1
16	03608	IDLER PULLEY, Main Belt	1	48	07065	KEY SWITCH, Electric (B. & S. Vanguard)	1
17	200676	SPACER, Main Belt Idler Arm	1	49	09052	DASHBOARD	1
18	06008	BUSHING, Axle Pivot Bar	2	50	07110	CHOKE CABLE	1
19	02114	BOLT, Wheel, 7/16" - 20	0	51	201279	HOLDER, Adjustable, Gas Tank	1
20	02603	CAP, Dust, 7/8"	2	52	07071	STEERING WHEEL, Spline Shaft	1
21	09054	BALL JOINT, Drag Link	2	53	07072	SEAT	1
22	06113	BEARING, Wheel Hub, Heim, 2" OD	4	54	200766	BRACKET, Dashboard	2
23	07137	TIRE, Front (Tire Only) 16-650 x 8	2	55	202103	BRACE, Steering Column	1
24	07138	Wheel, Front (with bearing, less tire)	2	56	07019	CLAMP	1
25	202466	WHEEL ASSEMBLY, Front (With Tire)	2	57	07075	TIRE & WHEEL, Rear, Complete, 8 x 12	2
26	09023	DRAGLINK	1	58	200503	ADAPTOR, Motor Base, B. & S. Vanguard	2
27	06009	BUSHING, Front Axle, 1-5/64" OD	4	59	200546	GUIDE, Belt, Engine Pulley, B. & S. Vanguard, Lower	1
28	200359	KINGPIN, Left	1	60	08049	STUD, 5/16" - 24 x 6"	1
29	200674	BUSHING, Tie Rod End	2	61	201395	STUD, Belt Guide	1
30	07139	TIE ROD END, Left	1	62	201597	GAS LINE, Fuel Tank to Valve	1
31	200350	FRONT AXLE UNIT	1	63	201509	Guide, Belt	1
32	07001	TIE ROD	1	64	02250	NUT, Lug, 7/16" -20	10

*See Electrical Schematic, Page 25

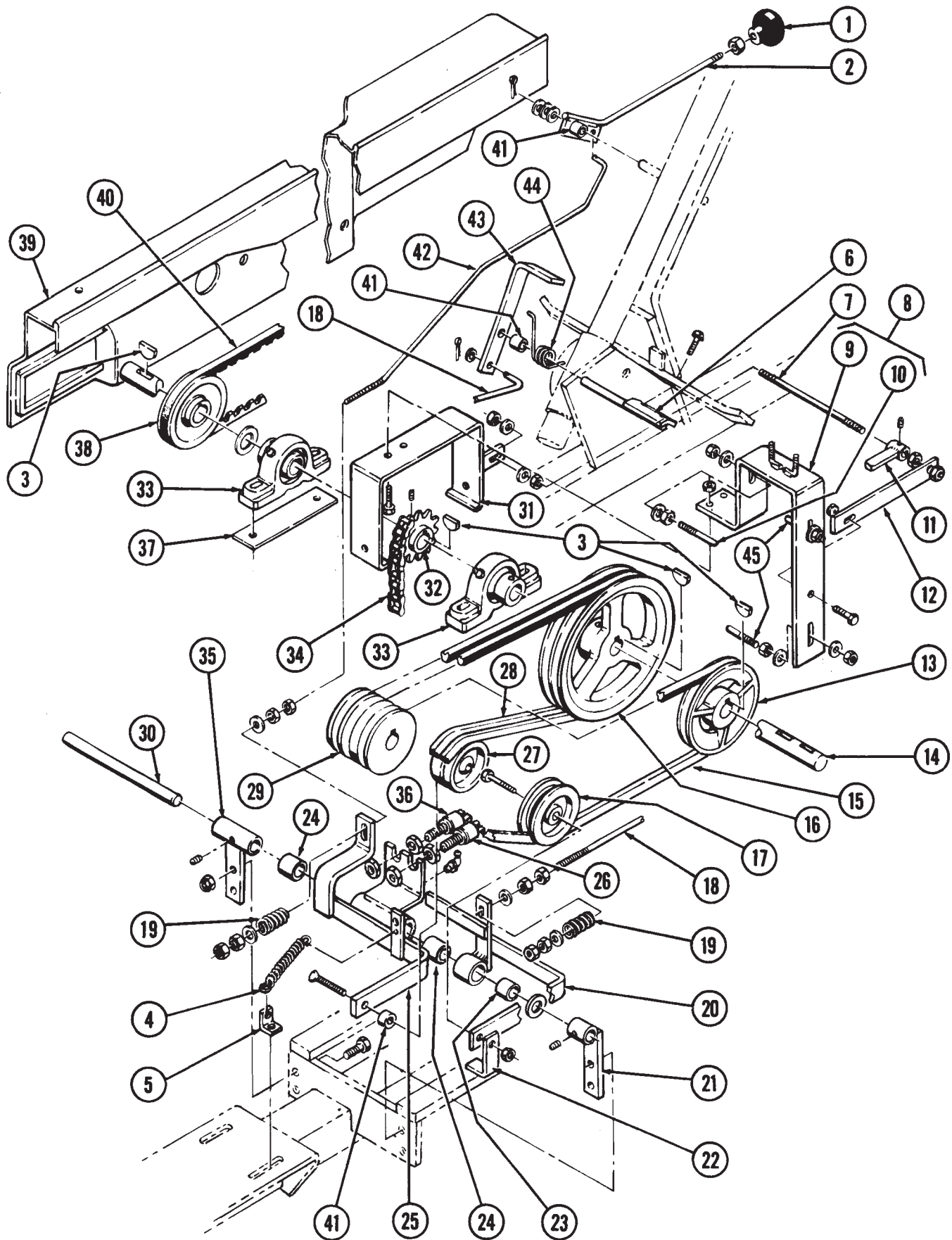

FIGURE 2

FIGURE 2 — CLUTCH DRIVE

Item	Part No.	Description	Qty.
1	07024	KNOB, Shifter	1
2	200509	LEVER, Main Mowing Clutch	1
3	202436	KEY, Woodruff, #9	4
4	04534	SPRING, Main Clutch	1
5	201607	BRACKET, Return Spring, Clutch	1
6	200531	SUPPORT PIVOT	1
7	08053	STUD, Chain Guard	1
8	200395	GUIDE ASSEMBLY, Belt Clutch Shaft	1
9	200396	GUIDE, Belt, Clutch Shaft	1
10	08047	STUD, Belt Guide, Inside	1
11	200392	GUIDE, Belt, Main Clutch	1
12	200757	PLATE, Belt Guide	1
13	03615	PULLEY, Transport Clutch, 5" O.D., 7/8" I.D.	1
14	200368	SHAFT, Clutch	1
15	03913	BELT, Transport Clutch, A42 Special	1
16	03614	PULLEY, Main Mowing Clutch, Two Groove	1
17	03607	PULLEY, Idler, Transport Clutch	1
18	202444	LINK, Transport Clutch	1
19	04527	SPRING	2
20	200777	LEVER, Transport Clutch	1
21	201695	CLUTCH PIVOT CARRIER, Left Hand	1
22	200530	GUIDE, Transport Clutch Belt	1
23	06002	BUSHING	1
24	06006	BUSHING	2
25	201474	IDLER ARM, Main Mowing Clutch	1
26	07090 *	SWITCH, Safety	1
27	03617	PULLEY, Idler, Main Mower Shaft	1
28	03914	BELT, Mowing Clutch, A48 Double	2
29	200762	PULLEY, Briggs & Stratton Engine, 1" I.D.	1
30	201770	SHAFT, Idler Pivot	1
31	201713	GUARD, Chain	1
32	03103	SPROCKET, Clutch, #50 Chain, 12 Tooth	1
33	06109	PILLOW BLOCK & BEARING (Complete)	2
34	07048	CHAIN, Countershaft, #50, 40 Pitch	1
35	201696	CLUTCH PIVOT CARRIER, Right Hand	1
36	07035 *	SWITCH, Safety, N/O	1
37	09026	SHIM, 1/32", Clutch Bearing Carrier	AR
38	03613	PULLEY, Countershaft, Slow Down, 4-1/2" O.D., 7/8" I.D.	1
39	09033	SHIELD, Main Drive Belt	1
40	03909	BELT, Main Drive, Notched, BX83	1
41	06012	BUSHING, Pivot	3
42	202442	LINK, Main Mowing Clutch	1
43	200829	PEDAL, Transport	1
44	04524	SPRING, Pedal	1
45	08046	STUD, Belt Guide, Outside	2

*See Electrical Schematic, Page 19

FIGURE 3

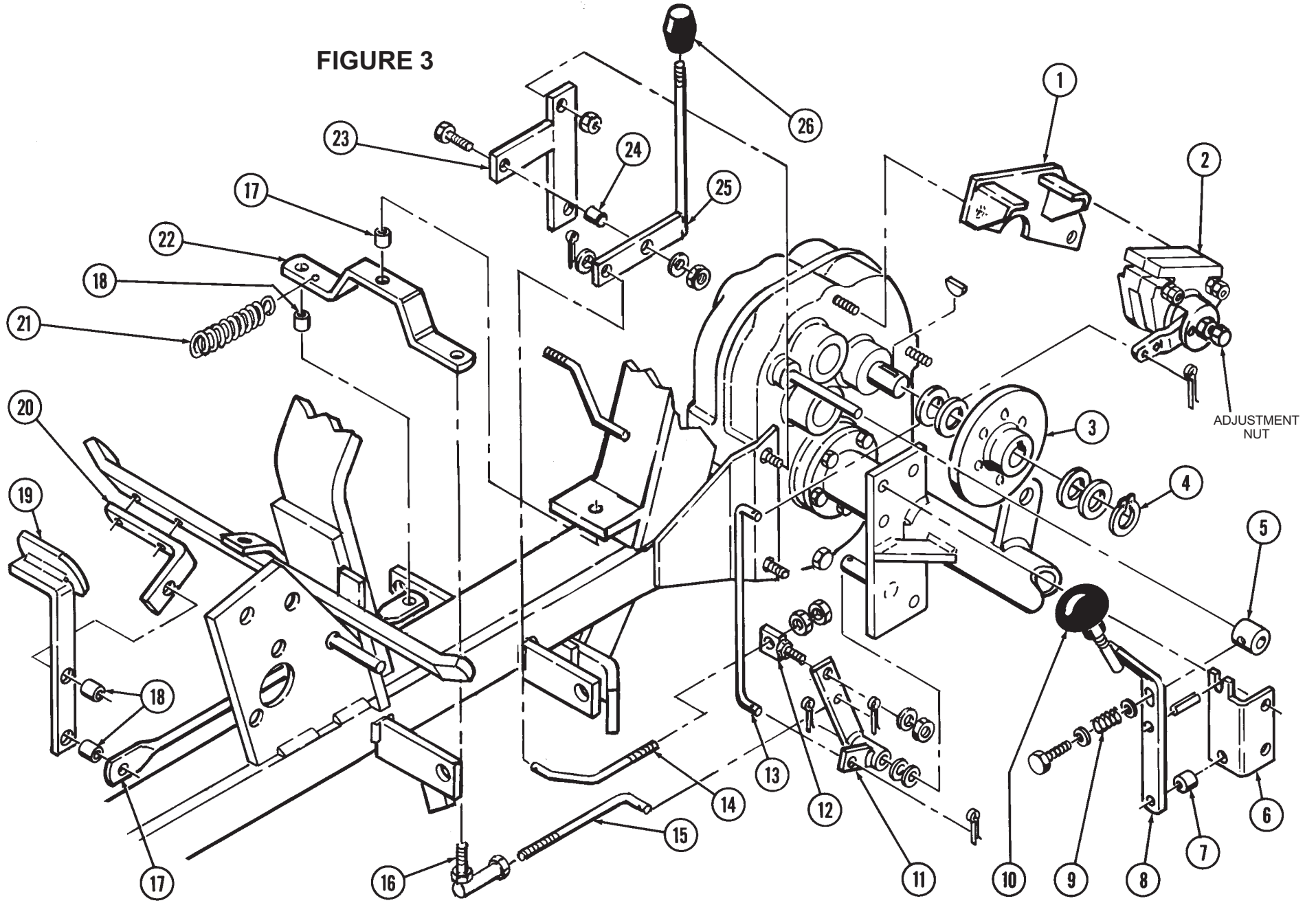

FIGURE 3 — GEAR SHIFT & BRAKE ASSEMBLY

Item	Part No.	Description	Qty.
1	200667	PLATE, Caliper Mount	1
2	07054	CALIPER, Brake	1
3	200486	DISC, Brake	1
4	04020	SNAP RING, 7/8" Diameter	1
5	200388	COLLAR, Gear Shifter	1
6	200478	BRACKET, Gear Shifter	1
7	200466	COLLAR, Shifter Lever	1
8	200479	SHIFTER LEVER, Differential Case	1
9	04507	SPRING, Shifter Lever	1
10	07024	KNOB	1
11	200482	PIVOT, Brake	1
12	201453	SLIDE, Parking Brake	1
13	08012	LINKAGE, Brace, Upper	1
14	08038	ROD, Formed, Parking Brake	1
15	08013	LINKAGE, Brace, Lower	1
16	07053	JOINT, Ball	1
17	200497	ROD, Brake Linkage	1
18	200676	SPACER	4
19	200493	LEVER, Foot Brake	1
20	200496	BRACKET, Foot Brake Lever	1
21	04520	SPRING, Brake Return	1
22	200488	PIVOT, Brake	1
23	201457	MOUNT, Parking Brake	1
24	200466	SPACER	1
25	201452	LEVER, Parking Brake	1
26	07181	KNOB	1

FIGURE 4 — LOWER COUNTERSHAFT ASSEMBLY

Item	Part No.	Description	Qty.
1	200389	SHIELD, Wing Mower Pulley, Right	1
2	202436	KEY, Woodruff, #9	4
3	03919	BELT, Wing Mower, B42, 5L450	1
4	200373	COUNTERSHAFT, Lower	1
5	200382	BELL CRANK, Wing Mower Clutch	1
6	07007	GRIP, Plastic	1
7	200377	GUIDE, Bell Crank, Wing Mower	1
8	200371	BEARING CARRIER (Less Bearings)	1
9	200385	SHIELD, Wing Mower Pulley, Left	1
10	03615	PULLEY, Countershaft, 5" O.D., 7/8" I.D.	2
11	06110	BEARING, Lower Countershaft	2
12	04510	SPRING, Countershaft Clutch, Wing Mower	1
13	200374	SLIDING CLUTCH JAW	1
14	05022	PIN, Lower Countershaft Sprocket	2
15	200698	SPROCKET, Lower Countershaft, 24 Tooth	1
16	06009	BUSHING, Lower Countershaft Sprocket	2
17	202375	COLLAR, Lower Countershaft, 7/8" I.D.	1
18	04511	SPRING, Clutch Bell Crank Lever	1
19	07090	SWITCH, Safety	1

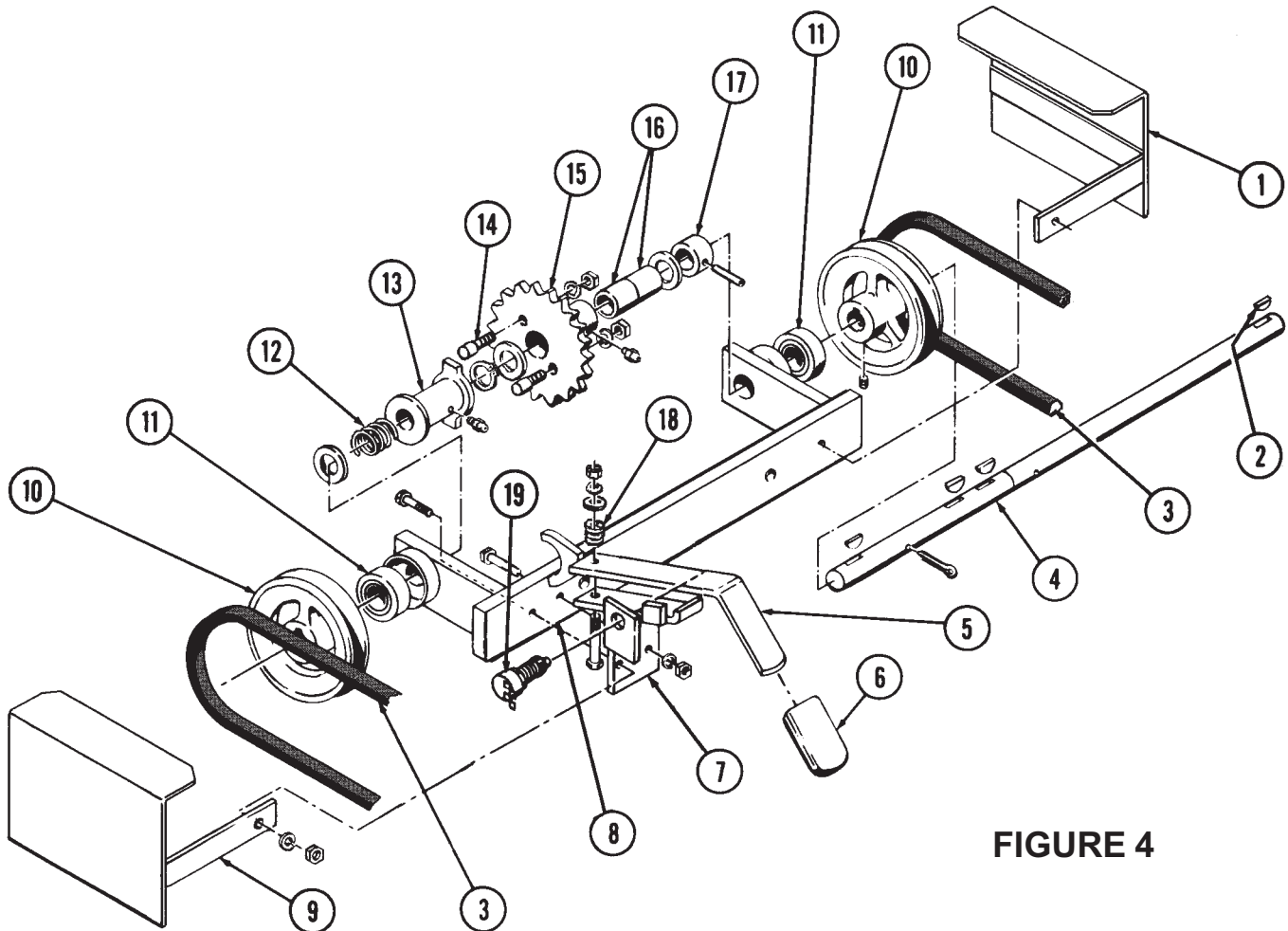

FIGURE 4

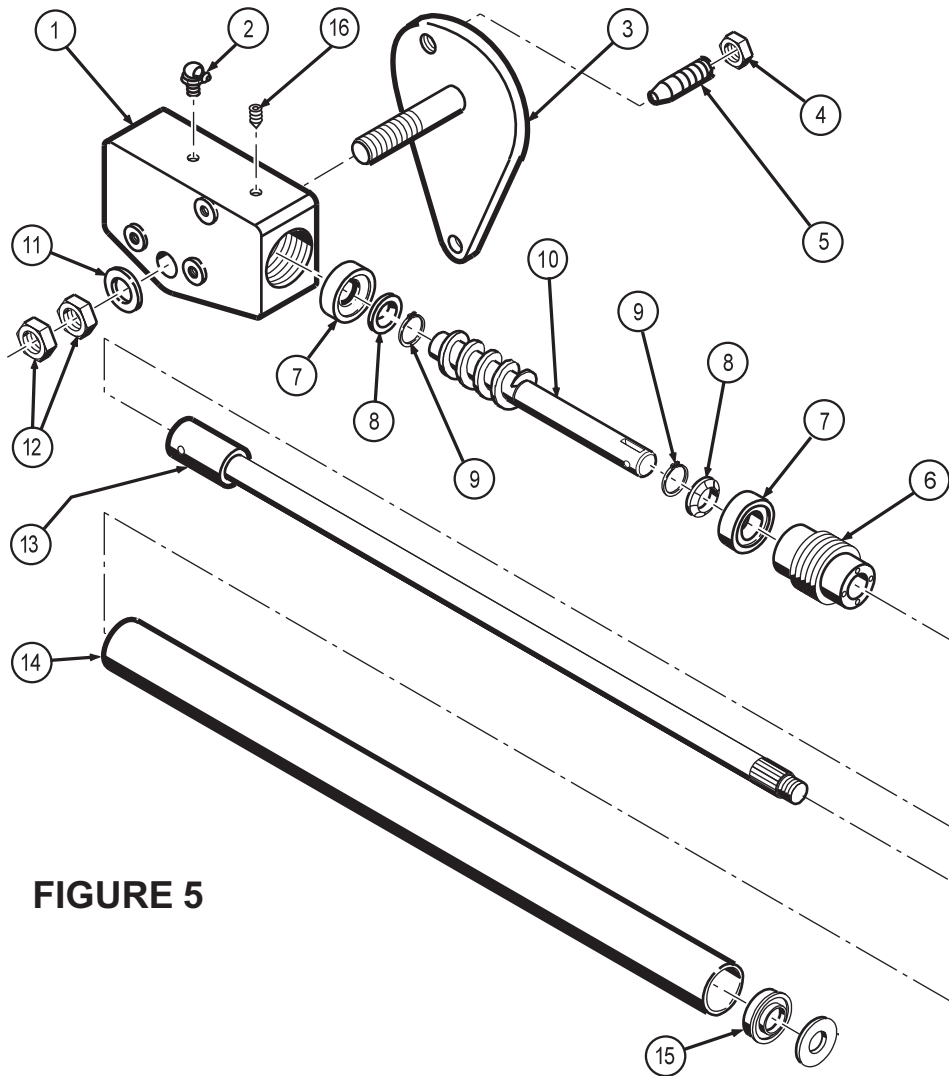

FIGURE 5

FIGURE 5 — STEERING GEAR ASSEMBLY, 201141

Item	Part No.	Description	Qty.
1	201147	HOUSING	1
2	07149	GREASE FITTING, 90o	1
3	201129	PITMAN ARM	1
4	02236	NUT,Hex Jam	1
5	201257	PIN	1
6	05001	ADJUSTER	1
7	06118	BEARING	2
8	05050	COLLAR	2
9	04011	LOCK RING	2
10	200830	STEERING GEAR	1
11	02409	WASHER	1
12	02240	NUT, Hex Jam, 3/4"	2
13	201139	SHAFT, Steering	1
14	201140	TUBE	1
15	06112	BEARING	1
16	04007	SET SCREW, 5/16" x 18, Cup Point	1

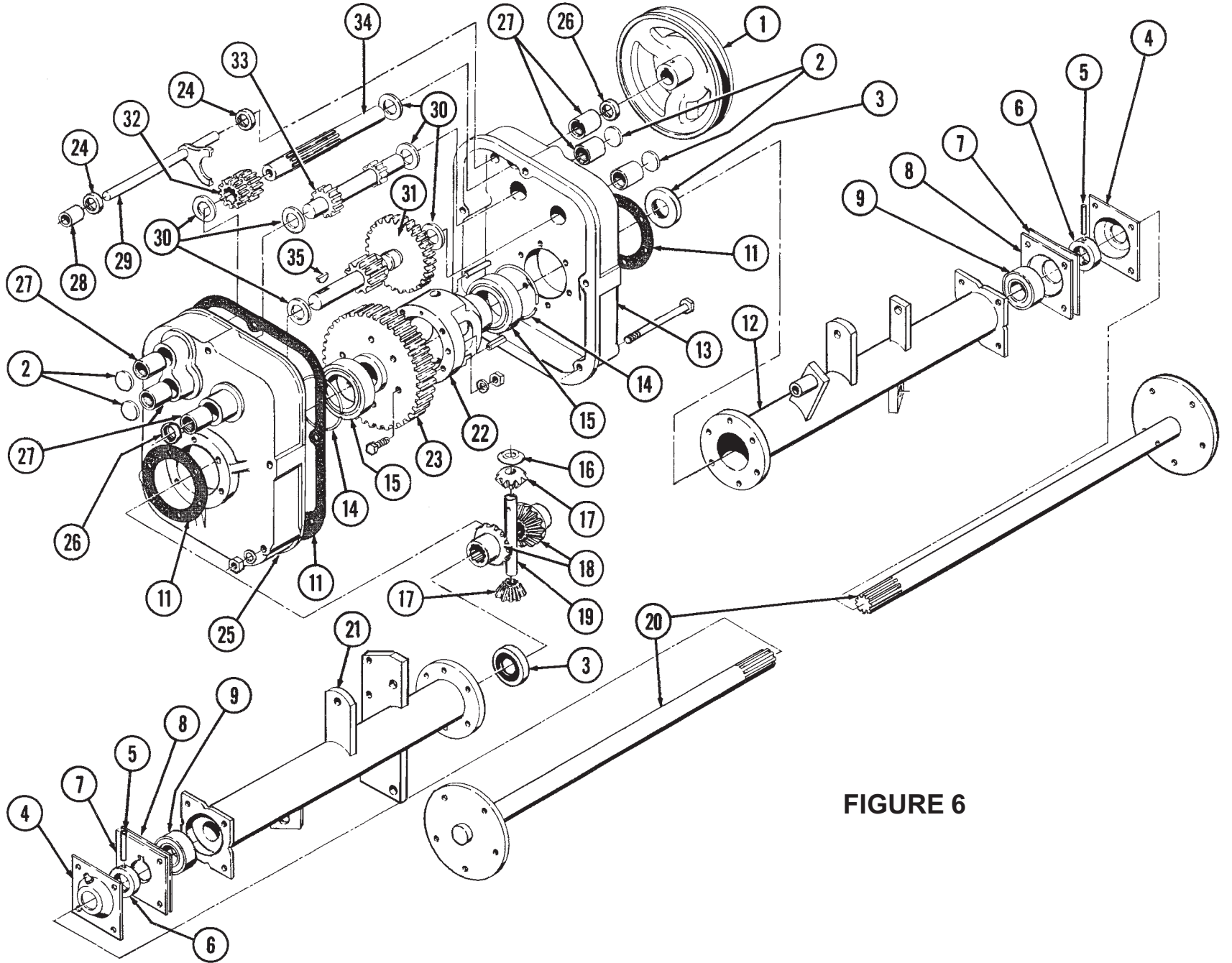

FIGURE 6

FIGURE 6 — DIFFERENTIAL & REAR AXLE

Item	Part No.	Description	Qty.
1	200426	PULLEY, Step	1
2	04049	PLUG, Differential Case, Welch	4
3	03512	OIL SEAL, Axle Housing	2
4	200096	CAP, Outer, Rear Axle	2
5	04016	PIN, Axle	2
6	200095	COLLAR, Rear Axle	2
7	200686	SHIM, Outer, Rear Axle, 1/8" x 1-3/16"	AR
	200821	SHIM, Outer, Rear Axle, 1/16"	AR
8	09046	SHIM, Outer, Rear Axle, 1/8" x 2-1/8" I.D.	AR
	09047	SHIM, Outer, Rear Axle, 1-32"	AR
9	06104	BEARING, Outer, Rear Axle	2
10	-----	NOT USED	
11	07006	GASKET SET, Differential Case	1
12	200427	AXLE HOUSING, Right Hand	1
13	200422	DIFFERENTIAL CASE, Right Hand	1
14	04519	SPACER, Differential Bearing	2
15	06108	BEARING, Differential Case	2
16	200405	WASHER, Pinion, Bevel Gear	1
17	03011	BEVEL GEAR, Pinion, Differential	2
18	03010	BEVEL GEAR, Side, Differential	2
19	200406	SHAFT, Differential Pinion	1
20	200441	AXLE, Rear	2
21	200437	AXLE HOUSING, Left Hand	1
22	200402	CAGE, Differential	1
23	200399	BULL GEAR, (Including Hub)	1
24	03517	SEAL, Oil, Shifter Fork	2
25	200398	DIFFERENTIAL CASE, Left Hand	1
26	03506	OIL SEAL, Needle Bearing	2
27	06107	BEARING, Needle, Differential Case	6
28	200419	SHIFTER FORK	1
29	200388	LUG, Gear Shifter	1
30	200407	THRUST WASHER, Differential Case	6
31	200408	INTERMEDIATE GEARS (Including Shaft)	1
32	200414	GEAR, Shifter Input, 12 Tooth	1
33	200415	GEAR, Reverse (Including Shaft)	1
34	200413	GEAR, Input (Spined Shaft)	1
35	04013	KEY, Woodruff, #11	1

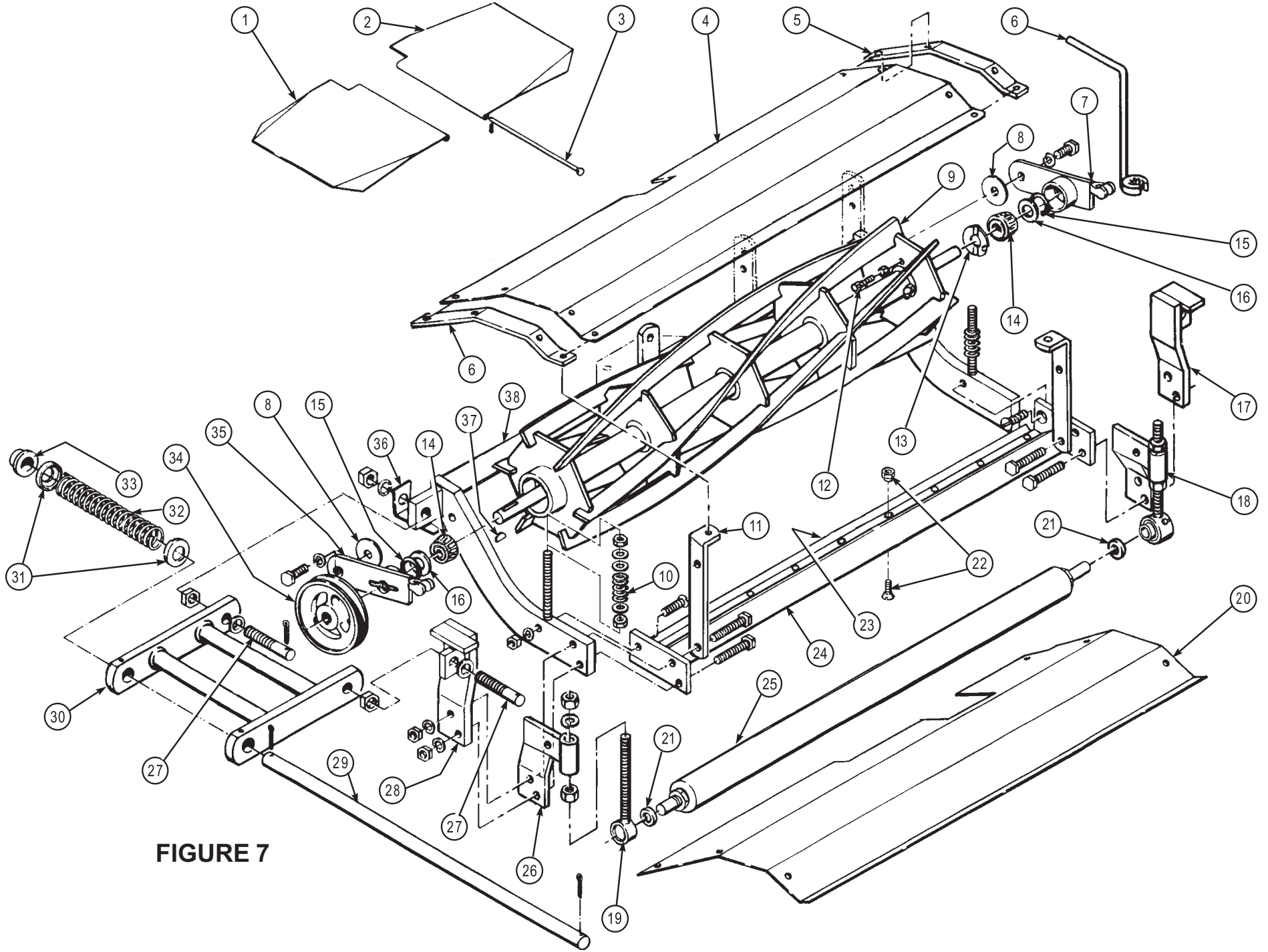

FIGURE 7

FIGURE 7 — REAR & WING MOWERS

Item	Part No.	Description	Qty.	Item	Part No.	Description	Qty.
1	200364	FOOT REST, Left	1	20	202076	SHIELD, Rear Mower	1
2	200365	FOOT REST, Right	1	21	06119	BEARING, Cup and Cone	6
3	200366	ROD, Foot Rest Hinge	2	22	02109	SCREW, Bed Knife (qty. per reel)	9
4	202090	SHIELD, Wing Mower, 1995 & Up, Right & Left	2		201802	NUT, Bed Knife (qty. per reel)	9
	202076	SHIELD, Rear Mower, 1995 & Up	1	23	201407	BED KNIFE, Bolt On	3
5	202073	BRACE	6		200722	BED KNIFE, Lo Cut	3
6	200644	WRENCH, Reel Adjustment	1	24	201841	BED KNIFE FRAME, Bolt On	3
7	200581	REEL CARRIER, Right	3	25	203173	ROLLER	3
8	02622	WASHER, Bearing Carrier	6	26	203471	ROLLER BRACKET ASSY., Left Hand	3
9	200572	REEL, 6 Blade	3		203131	ROLLER BRACKET (only), Left Hand	3
	200839	REEL, 8 Blade	3	27	200598	YOKE PIN, Wing Mower	2
10	04535	SPRING, Reel Adjuster	6	28	200640	REAR YOKE BRACKET, Wing Mower, Right	2
11	202072	BRACE, Grass Shield	6	29	200363	PULL ROD, Wing Mower	2
12	200256	ADJUSTING SCREW & NUT, Bearing		30	200360	PULL YOKE, Wing Mower	2
13	201437	ADJUSTER, Reel Bearing	3	31	02602	DUST CAP, 3/4" I.D.	4
14	06120	BEARING, Reel	6	32	04521	SPRING, Wing Mower Pull Yoke	2
	06121	CUP, Reel	6	33	200133	BUSHING, Wing Mower Pull Rod	2
15	03508	O-RING	6	34	03606	PULLEY, Wing Mower, 4-7/8" O.D.	2
16	02621	WASHER	6	35	200584	REEL CARRIER, Left	2
17	200587	REAR YOKE BRACKET, Wing Mower, Left	2	36	201782	SCRAPER, Pulley	2
18	203470	ROLLER BRACKET ASSY., Right Hand	3	37	04013	KEY, Woodruff, #11	3
	203133	ROLLER BRACKET (only), Right Hand	3	38	200559	MOWER FRAME, Right Hand	1
	200751	ADJUSTER, Roller Bracket, Right Hand	3		200560	MOWER FRAME, Left Hand	1
19	200636	ADJUSTER, Roller Bracket, Left Hand	3		200601	MOWER FRAME, Rear	1

FIGURE 8

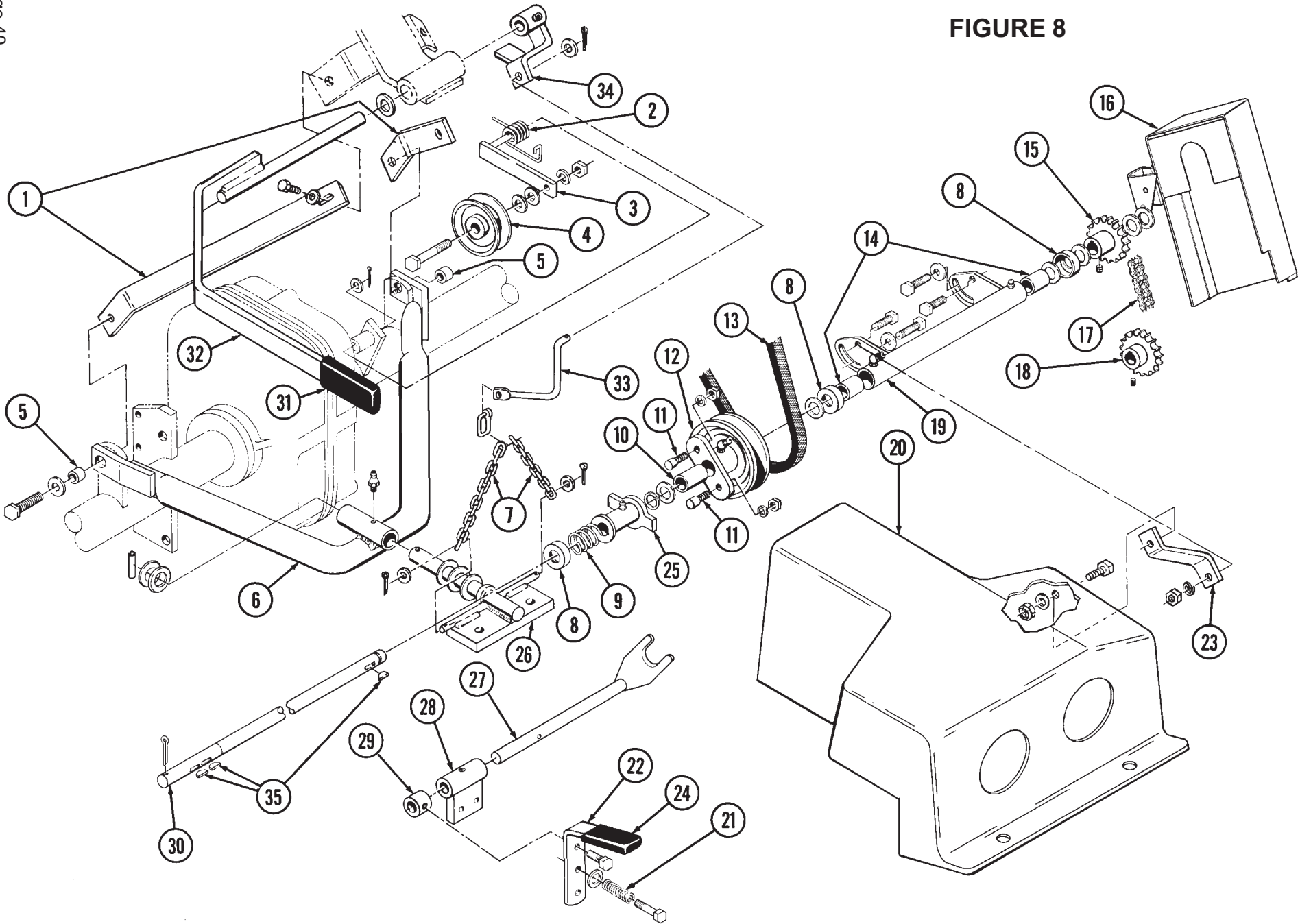

FIGURE 8 — REAR MOWER LIFT & DRIVE PARTS

Item	Part No.	Description	Qty.
1	200450	BRACE, Rear Mower Lift	2
2	04517	SPRING, Torsion, Rear Mower	1
3	200475	ARM, Idler, Rear Mower	1
4	03607	PULLEY, Idler	1
5	200468	BUSHING, Pull Yoke, Rear Mower	2
6	200469	PULL YOKE, Rear Mower	1
7	07050	CHAIN, Lifter, Rear Mower	2
8	02602	DUST CAP, 3/4" I.D.	3
9	04506	SPRING, Clutch, Rear Mower	1
10	06011	BUSHING, Clutch Pulley, Rear Mower	1
11	05022	PIN, Pulley	2
12	200608	PULLEY, Clutch, Rear Mower	1
13	03911	BELT, Rear Mower, 5L500, B47	1
14	06006	BUSHING, Countershaft, Rear Mower	2
15	03107	SPROCKET, Countershaft, 20 Tooth	1
16	200611	GUARD, Chain, Rear Mower	1
17	07077	CHAIN, Rear Mower, #40, 47 Pitch	1
	07078	LINK, Chain, Rear Mower	AR
18	03108	SPROCKET, Rear Mower, 15 Tooth	1
19	200705	HOUSING, Countershaft, Rear Mower	1
20	09044	GUARD, Clutch, Rear Mower	1
21	202438	SPRING, Shifter Lever	1
22	203567	LEVER, Clutch Shifter, Rear Mower	1
23	200613	BRACKET, Guard	1
24	07022	GRIP, Plastic, Shifter	1
25	200266	CLUTCH, Sliding Jaw, Rear Mower	1
26	200458	PULL PLATE, Rear Mower	1
27	200271	SHIFTER YOKE, Rear Mower	1
28	200273	BRACKET, Clutch Lever, Rear Mower	1
29	200388	COLLAR, Clutch, Rear Mower	1
30	200610	COUNTERSHAFT, Rear Mower	1
31	07039	GRIP, Lifter Handle	1
32	200451	HANDLE, Lifter, Rear Mower	1
33	08030	PULL ROD, Rear Mower Lifter	1
34	200454	PIVOT, Rear Mower Lifter	1
35	202436	KEY, Woodruff, #9	3

ELECTRICAL PARTS
See Electrical Schematic

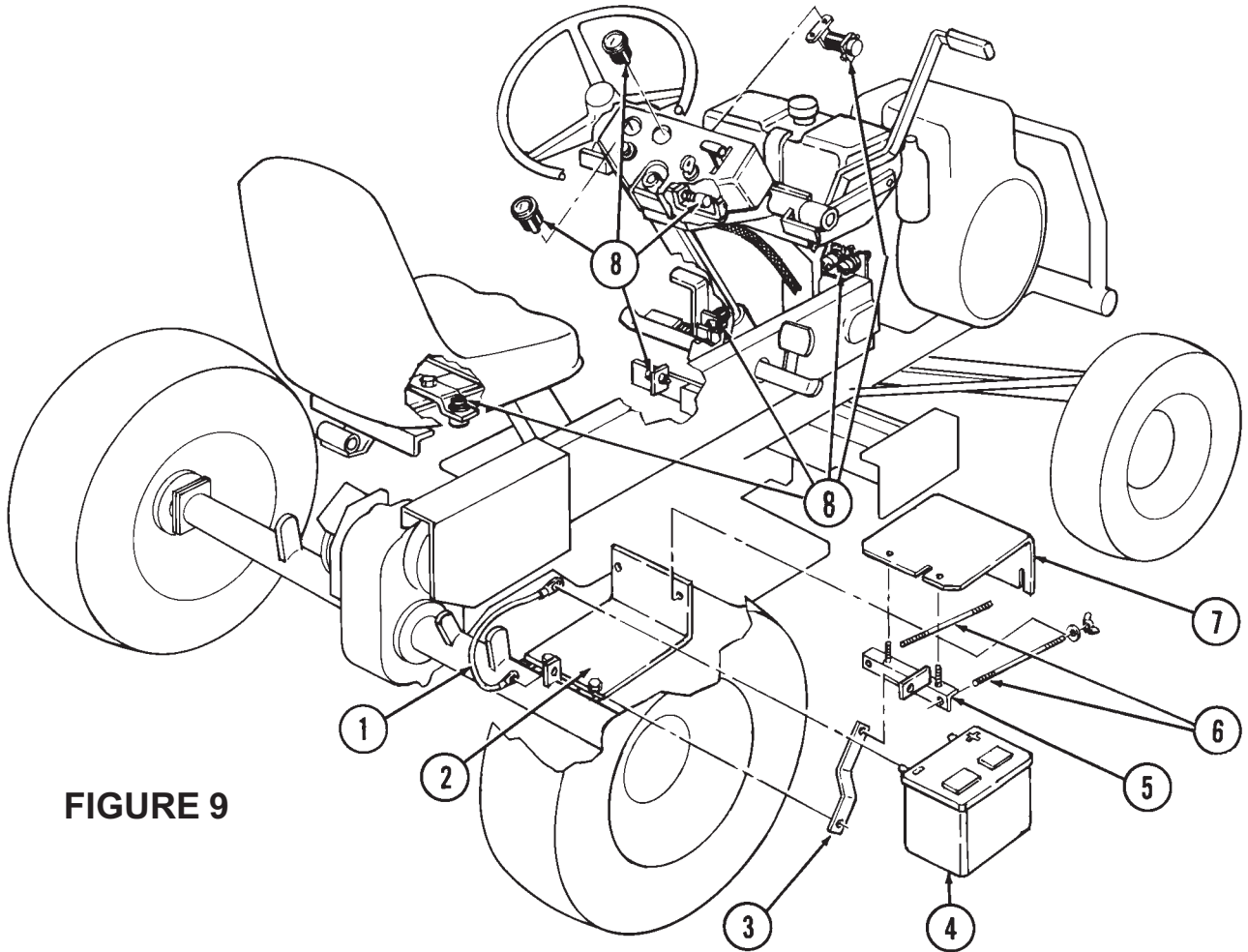

FIGURE 9

FIGURE 9— BATTERY & ELECTRICAL PARTS

Item	Part No.	Description	Qty.
1	07104	GROUND WIRE	1
2	201482	PLATE, Battery Box, Bottom	1
3	200774	BRACE, Sidepost Battery Box	1
4	-----	BATTERY (User Supplied, Obtain Locally)	1
5	201492	HOLDDOWN, Sidepost Battery	1
6	08033	ROD, Sidepost Battery	2
7	09083	COVER, Battery, 1993 and up	1
8	-----	ELECTRICAL SYSTEM - See Electrical Diagram, Page 25 for part numbers of components for your particular engine.	1

FIGURE 10

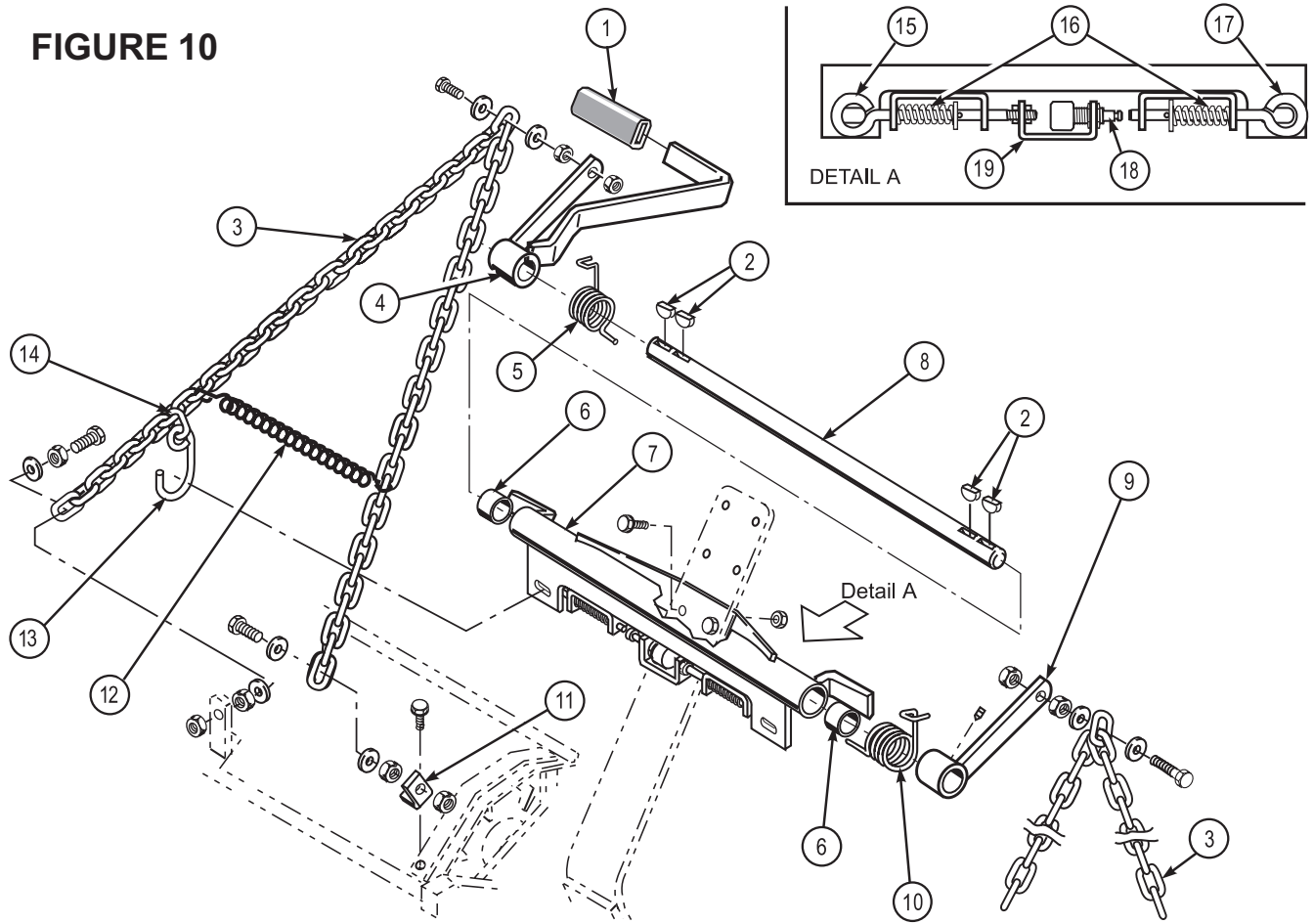

FIGURE 10 — MANUAL WING MOWER LIFT
No. 480041

Item	Part No.	Description	Qty.
1	07230	GRIP, Lift Handle	1
2	04013	KEY, Woodruff	4
3	201663	LIFT ASSEMBLY	2
4	201659	LIFT HANDLE	1
5	04533	SPRING, Lift Handle, Right Hand	1
6	06026	BUSHING	2
7	201661	HOOK BRACKET WELDMENT	1
8	201646	SHAFT, Lift	1
9	201660	LEVER, Lift	1
10	04538	SPRING, Lift Handle, Left Hand	1
11	201647	BRACKET, Cable	2
12	04547	SPRING	2
13	201662	HOOK	2
14	07051	OPEN LINK	2
15	201650	SWITCH ROD, Left Hand	1
16	202439	SPRING, Switch Rod	2
17	201649	SWITCH ROD, Right Hand	1
18	07090	SAFETY SWITCH	1
19	201648	SWITCH BRACKET	1

**FIGURE 11 — ROLLER SCRAPER KIT
480067 (set of 3)**

Item	Part No.	Description	Qty.
1	302864	ADJUSTER, Left Hand	3
2	02228	NUT, Jam, 5/16"-24	12
3	09183	CABLE, Roller Scraper	3
4	302865	ADJUSTER, Right Hand	3

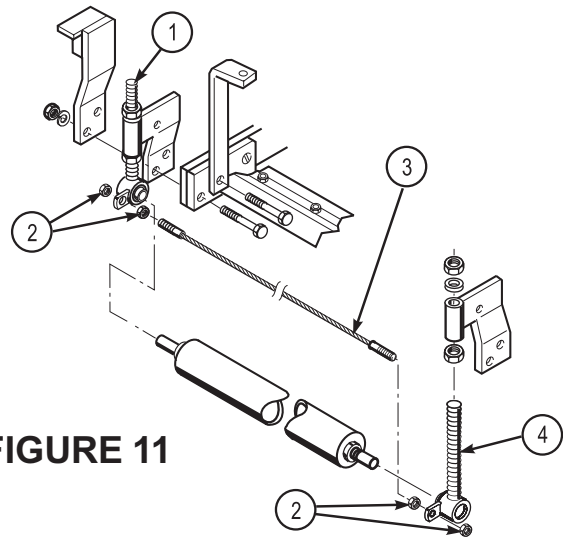

FIGURE 11

**FIGURE 12 — ANTI SCALP ROLLER KIT
480060 (set of 2)**

Item	Part No.	Description	Qty.
1	02021	SCREW, Hex Hd., 5/16"-24 x 2-1/2"	2
2	02238	NUT, Hex Jam, 5/8"-11	4
3	202074	BRACKET, Roller, 1995 & Up	2
4	02402	WASHER, Flat, 5/16" SAE	4
5	02262	NUT, Hex Lock, 5/16"-24	2
6	200636	ADJUSTER, Roller Bracket	2
7	07045	ROLLER	2
8	02503	WASHER, Adjustment	4
9	201821	SHAFT, Roller	1

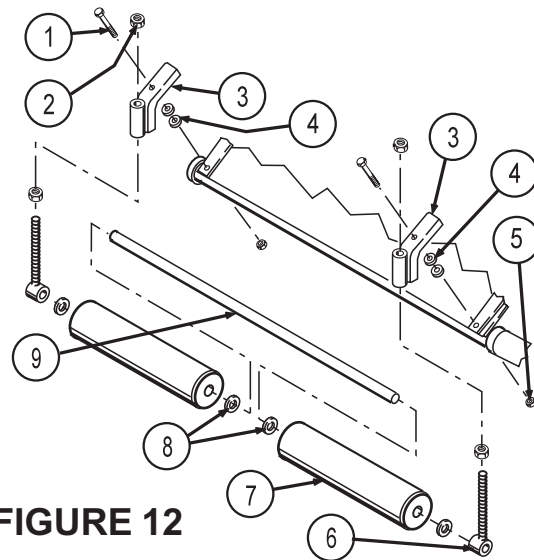

FIGURE 12

FIGURE 13

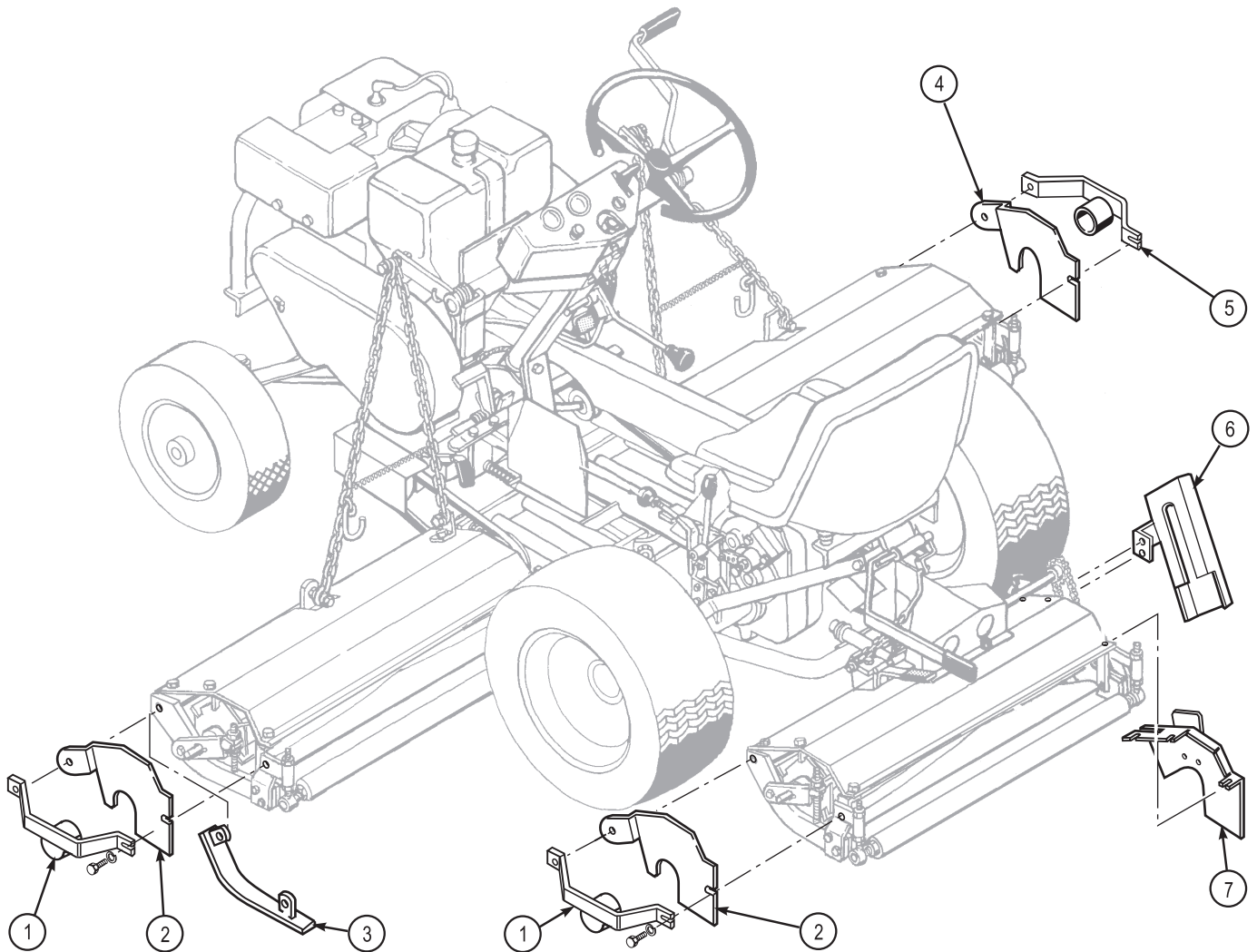

FIGURE 13 — SKIDS, REEL END MOWER SHIELDS & GUARD

Item	Part No.	Description	Qty.
1	203674	SKID BAR, Left Hand	2
2	202960	MOWER SHIELD, Wing Mower & Rear Mower, L.H.	2
3	201283	SKID, Wing Mower, Left Hand	1
	201284	SKID, Wing Mower, Right Hand	1
4	202961	MOWER SHIELD, Wing Mower, Righ Hand	1
5	203675	SKID BAR, Right Hand	1
6	202411	CHAIN GUARD WELDMENT, Rear Mower	1
7	202332	SHIELD, Rear Mower, Right Hand	1

